

Panasonic



Compact Plain Paper Fax
with 2.4 GHz Cordless
and Answering System

Operating Instructions

Model No. **KX-FPG372**



FOR FAX ADVANTAGE ASSISTANCE:

- (VOICE) CALL
1-800-HELP-FAX (1-800-435-7329)
- E-MAIL TO
consumerproducts@panasonic.com
for customers in the U.S.A. or Puerto Rico
- REFER TO
www.panasonic.com
for customers in the U.S.A. or Puerto Rico

Please read these Operating Instructions before using the unit and save for future reference.

This model is designed to be used only in the U.S.A.

Battery charge

Place the handset on the cradle of the base unit for about **15 hours** before initial use.

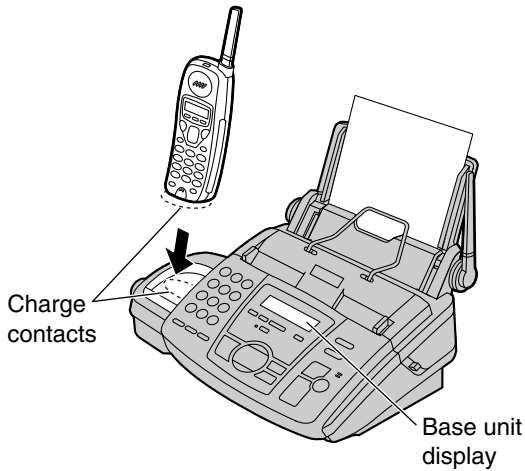

- A beep will sound, and the following will be displayed for an instant on the base unit.

Base unit display:

CHARGING

The display will show the date and time.

- For further details, see page 21.

Operating distance and noise

Calls are transmitted between the base unit and the handset using wireless radio waves.

For maximum distance and noise-free operation, the recommended base unit location is:

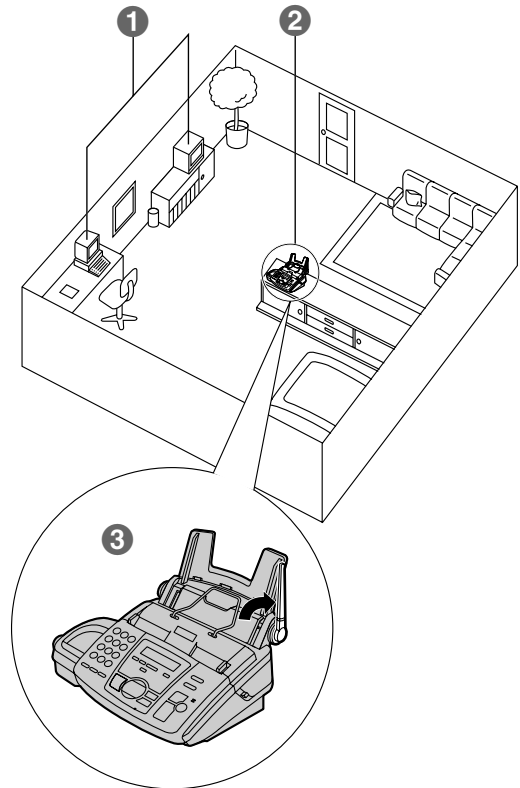

- 1 **Away from electrical appliances such as a TV, personal computer or another cordless phone.**
- 2 **In a HIGH and CENTRAL location with no obstructions such as walls.**
- 3 **Raise the antenna vertically.**

Note:

- If you are using the handset near a microwave oven which is being used, noise may be heard from the receiver on the handset. Move away from the microwave oven and closer to the base unit.
- If more than one cordless phone is being used and your handset is near another cordless phone's base unit, noise may be heard. Move away from the other cordless phone's base unit and closer to your base unit.

Safety Instructions

Important safety instructions

When using this unit, basic safety precautions should always be followed to reduce the risk of fire, electric shock, or personal injury.

1. Read and understand all instructions.
2. Follow all warnings and instructions marked on this unit.
3. Unplug this unit from power outlets before cleaning. Do not use liquid or aerosol cleaners. Use a damp cloth for cleaning.
4. Do not use this unit near water, for example near a bathtub, wash bowl, kitchen sink, etc...
5. Place the unit securely on a stable surface. Serious damage and/or injury may result if the unit falls.
6. Do not cover slots and openings on the unit. They are provided for ventilation and protection against overheating. Never place the unit near radiators, or in a place where proper ventilation is not provided.
7. Use only the power source marked on the unit. If you are not sure of the type of power supplied to your home, consult your dealer or local power company.
8. For safety purposes this unit is equipped with a grounded plug. If you do not have this type of outlet, please have one installed. Do not defeat this safety feature by tampering with the plug.
9. Do not place objects on the power cord. Install the unit where no one can step or trip on the cord.
10. Do not overload wall outlets and extension cords. This can result in the risk of fire or electric shock.
11. Never push any objects through slots in this unit. This may result in the risk of fire or electric shock. Never spill any liquid on the unit.
12. To reduce the risk of electric shock, do not disassemble this unit. Take the unit to an authorized service center when service is required. Opening or removing covers may expose you to dangerous voltage or other risks. Incorrect reassembly can cause electric shock when the unit is subsequently used.
13. Unplug this unit from the wall outlet and refer servicing to an authorized service center when the following conditions occur:
 - A. When the power supply cord or plug is damaged or frayed.
 - B. If liquid has been spilled into the unit.
 - C. If the unit has been exposed to rain or water.
 - D. If the unit does not work normally by following the operating instructions. Adjust only controls covered by the operating instructions. Improper adjustment may require extensive work by an authorized service center
 - E. If the unit has been dropped or physically damaged.
 - F. If the unit exhibits a distinct change in performance.
14. During thunderstorms, avoid using telephones except cordless types. There may be a remote risk of an electric shock from lightning.
15. Do not use this unit to report a gas leak, when in the vicinity of the leak.

SAVE THESE INSTRUCTIONS

INSTALLATION:

- Never install telephone wiring during a lightning storm.
- Never install telephone jacks in wet locations unless the jack is specifically designed for wet locations.
- Never touch uninsulated telephone wires or terminals unless the telephone line has been disconnected at the network interface.
- Use caution when installing or modifying telephone lines.

WARNING:

- To prevent the risk of fire or electrical shock, do not expose this product to rain or any type of moisture.

OTHER INFORMATION:

- Keep the unit away from electrical noise generating devices, such as fluorescent lamps and motors.
- The unit should be kept free from dust, high temperature and vibration.
- The unit should not be exposed to direct sunlight.
- Do not place heavy objects on top of this unit.
- Do not touch the plug with wet hands.

CAUTION:

Battery

To reduce the risk of fire or injury to persons, read and follow these instructions.

- Use only the battery(ies) specified.
- Do not dispose of the battery(ies) in a fire. They may explode. Check with local waste management codes for special disposal instructions.
- Do not open or mutilate the battery(ies). Released electrolyte is corrosive and may cause burns or injury to the eyes or skin. The electrolyte may be toxic if swallowed.
- Do not let the batteries come in contact with conductive materials such as rings, bracelets and keys or the battery and/or conductor may overheat and cause burns.
- Charge the battery(ies) provided with or identified for use with this product only in accordance with the instructions and limitations specified in this manual.

NOTICE:

- Operating near 2.4GHz electrical appliances may cause interference. Move away from the electrical appliances and/or press the CH (Channel) button.
- Consult the manufacturer of any personal medical devices, such as pacemakers, to determine if they are adequately shielded from external RF (radio frequency) energy. (The unit operates in the frequency range of 2402 MHz to 2480 MHz, and the power output level can range 0.015 watts.) Do not use the unit in health care facilities if any regulations posted in the area instruct you not to do so. Hospitals or health care facilities may be using equipment that could be sensitive to external RF (radio frequency) energy.

Table of Contents

Initial Preparation

Accessories	Included accessories	9
	Accessory information.....	10
Finding the Controls (Base Unit)	Location of controls	11
	Overview	12
Finding the Controls (Handset)	Location of controls	13
Setting (Base Unit)	Ink film	14
	Paper tray	16
	Metal recording paper guide	17
	Recording paper	18
Setting (Handset)	Belt clip and headset.....	19
Connections and Setup	Selecting the way to use your fax machine.....	20
	Case 1: Using the fax machine only	22
	Case 2: Using the fax machine with an extension telephone	24
	Case 3: Using the fax machine with a computer.....	26
Help Button	Help function	28
Volume	Adjusting handset volume	29
	Adjusting base unit volume	30
Initial Programming	Date and time, your logo and fax number.....	31

Telephone

Making and Answering Calls	Phone calls - making.....	35
	Phone calls - answering	37
	Intercom	38
	Transferring a call	40
Navigator Directory	Storing names and telephone numbers into the navigator directory....	41
	Editing a stored entry	43
	Erasing a stored entry	45
	Making a phone call using the navigator directory	47
Caller ID	Caller ID service from your phone company	49
	Viewing and calling back using caller information.....	50
	Erasing caller information	52
	Storing caller information	54

Table of Contents

Fax

Sending Faxes	Sending a fax manually	55
	Documents you can send	57
	Sending a fax using the navigator directory	58
	Broadcast transmission	59
Receiving Faxes	Receiving a fax manually	62
	Receiving a fax automatically	64
Distinctive Ring	Using two or more phone numbers in a single telephone line	66

Copy

Copying	Making a copy	68
----------------	---------------------	----

Answering Device

Greeting	Recording your own greeting message	71
	Erasing your own recorded greeting message	72
Memo Message	Leaving a message for others or yourself	73
Incoming Messages	Listening to recorded messages using the base unit	74
	Listening to recorded messages using the handset	76
Remote Operation	Operating from a remote location	77
Voice Mailbox	How callers can leave you private messages	79
	Recording your own mailbox greeting messages	80
	Listening to recorded messages using the base unit	81
	Listening to recorded messages using the handset	82
	Listening to recorded messages from a remote location	83
Option	Transferring recorded messages to another telephone	84

Programmable Features

Features Summary	Programming	86
	Basic features	88
	Advanced features	89

Table of Contents







Help

Error Messages	Reports	93
	Display	94
Frequently Asked Questions	When a function does not work, check here	96
Replacement	Ink film.....	101
Jams	Recording paper jam.....	103
	Document jams – sending	106
Battery	Replacing the handset battery	107
Cleaning	Document feeder	108
	Thermal head.....	109

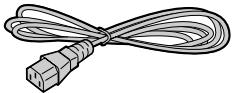
General Information

Printed Reports	Reference lists and reports	111
Caller IQ Feature	openLCR service for the Caller IQ feature	112
Specifications	Technical data about this product	119
FCC and Other Information	FCC and Other Information.....	121
Warranty	Limited Warranty	123
Customer Services	Customer Services directory	125
Index	Program index.....	126
	Index	127

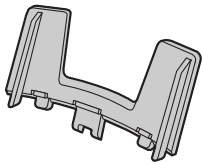
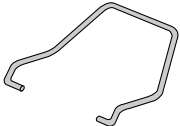
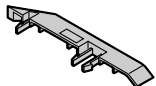
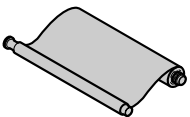
Included accessories

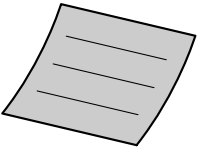
Power cord 1  Part No. PFJA1030Z	Telephone line cord.....1  Part No. PQJA10075Z	Cordless handset* 1 
Belt clip..... 1  Part No. PQKE10341Z3	Paper tray (for letter size recording paper)1  Part No. PFKS1060Z1	Metal recording paper guide 1  Part No. PFUS1385Z
A4 paper guide..... 1  Part No. PFZMFC175AL	Ink film1  – prints about 150 letter size pages.	Operating instructions 1  Part No. PFQX1792Z
Quick start sheet 1  Part No. PFQW1867Z		

* The cordless handset is shown as the KX-FPG371R on the label, but it can be also used for this model, KX-FPG372.

- If any items are missing or damaged, check with the place of purchase.
- Save the original carton and packing materials for future shipping and transportation of the unit.
- The part numbers are subject to change without notice.

Accessories

Accessory information

- We recommend that you buy the full-size, 50 meter (164') replacement roll for use in your unit. Please use genuine Panasonic replacement film. **The ink film is not reusable. Do not rewind and reuse it.**
- To install legal size recording paper, use the legal paper tray (page 16).

Model No.	Item	Specifications/Usage
KX-FA53	Replacement film	1 roll – 216 mm × 50 m (8 ¹ / ₂ " × 164') (about 150 letter size pages)
KX-FA55	Replacement film	2 rolls – 216 mm × 50 m (8 ¹ / ₂ " × 164') (about 300 letter size pages)
KX-FA55D	Replacement film	4 rolls – 216 mm × 50 m (8 ¹ / ₂ " × 164') (about 600 letter size pages)
KX-FA51	Legal paper tray	To install legal size recording paper.
P-P511	Rechargeable battery	Nickel cadmium battery for the cordless handset.
KX-TCA88/KX-TCA90	Headset	For a hands-free telephone conversation.

- To place an order:

Telephone: Call 1-800-332-5368.

Fax: Send a fax to 1-800-237-9080.

Include:

- your name, shipping address and telephone number,
- credit card type, number, expiration date and your signature,
- order part number and quantity.

Internet: Visit our web site: <http://www.panasonic.com/store>
(for customers in the U.S.A. ONLY)

- If you have any questions about internet orders, please contact us at:

E-mail: panasonicdirect@panasonic.com

Telephone: 1-866-888-2929

Finding the Controls (Base Unit)

Location of controls

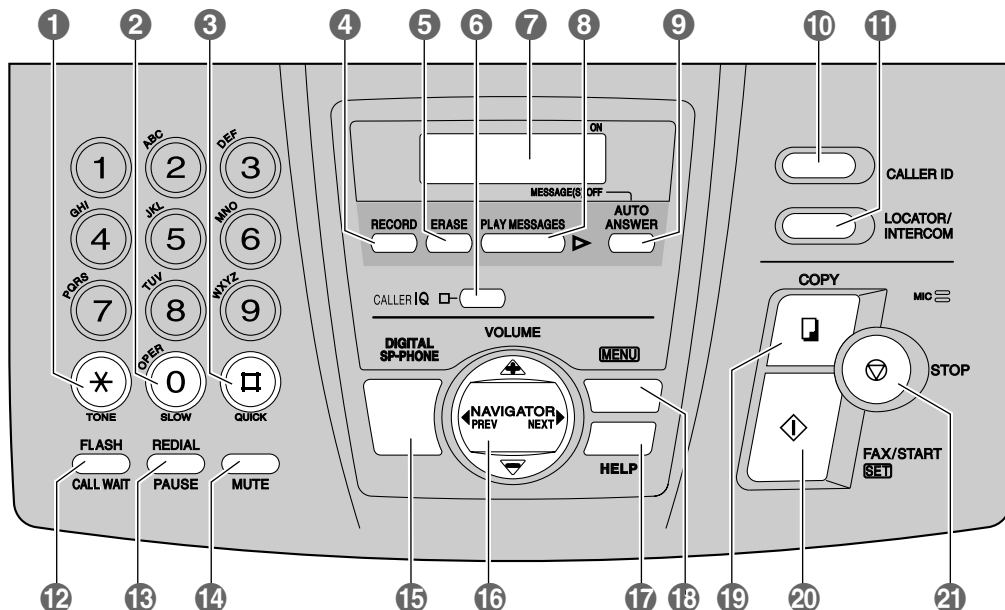

- 1 [TONE]**
 - To change from pulse to tone temporarily during dialing when your line has rotary pulse services.
- 2 [SLOW]**
 - For slow playback (page 74).
- 3 [QUICK]**
 - For quick playback (page 74).
- 4 [RECORD]**
 - To record your own greeting messages (page 71).
- 5 [ERASE]**
 - To erase recorded messages (page 75).
- 6 [CALLER IQ]**
 - To use the Caller IQ feature (page 113).
- 7 Display**
- 8 [PLAY MESSAGES]**
 - To play recorded messages (page 74).
- 9 [AUTO ANSWER]**
 - To turn on/off the auto answer setting (page 62, 64).
- 10 [CALLER ID]**
 - To use Caller ID service (page 51, 54).
- 11 [LOCATOR/INTERCOM]**
 - To page or locate the handset (page 39, 40).
- 12 [FLASH][CALL WAIT]**
 - To access special telephone services such as Call Waiting (page 49) or for transferring extension calls.
- 13 [REDIAL][PAUSE]**
 - To redial the last number dialed from the base unit.
 - To insert a pause during dialing or after pressing [FLASH].
- 14 [MUTE]**
 - To mute your voice to the other party during a conversation. Press this button again to resume the conversation.
- 15 [DIGITAL SP-PHONE]**
 - For speakerphone operation (page 36, 37).
- 16 [NAVIGATOR][VOLUME]**
 - To adjust volume (page 29).
 - To search for a stored name (page 47, 58).
 - To select the features or feature settings during programming (page 86, 87).
 - To navigate to the next operation.
- 17 [HELP]**
 - To print a quick reference (page 28).
- 18 [MENU]**
 - To initiate or exit programming.
- 19 [COPY]**
 - To initiate copying (page 68).
- 20 [FAX/START][SET]**
 - To initiate fax transmission or reception.
 - To store a setting during programming.
- 21 [STOP]**
 - To stop an operation or cancel programming.

Finding the Controls (Base Unit)

Overview

Front view

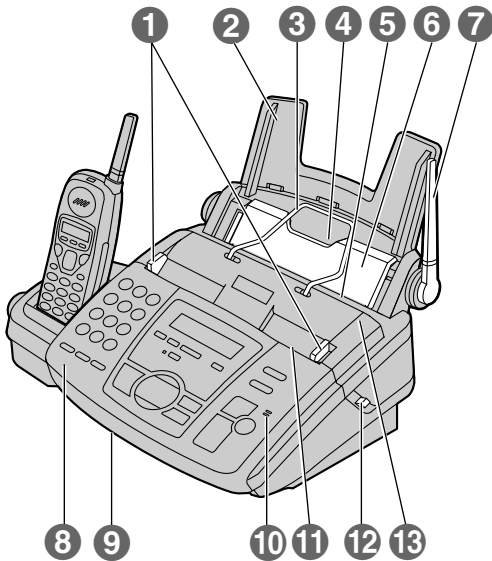

- 1 Document guides
- 2 Paper tray
- 3 Metal recording paper guide
- 4 Recording paper entrance
- 5 Recording paper exit
- 6 Tension plate
- 7 Antenna
- 8 Front cover
- 9 Document exit
- 10 Microphone
 - To talk with the other party when using the speakerphone.
- 11 Document entrance
- 12 Back cover open button
- 13 Back cover

Rear view

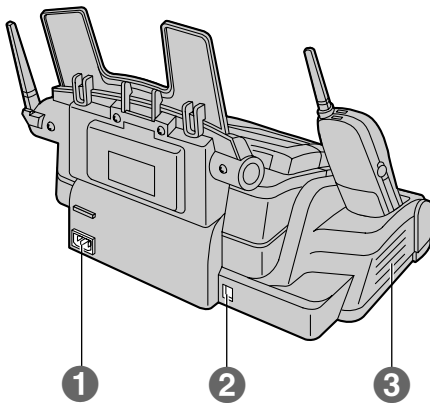

- 1 Power inlet
- 2 Telephone line jack
- 3 Speaker

Finding the Controls (Handset)

Location of controls

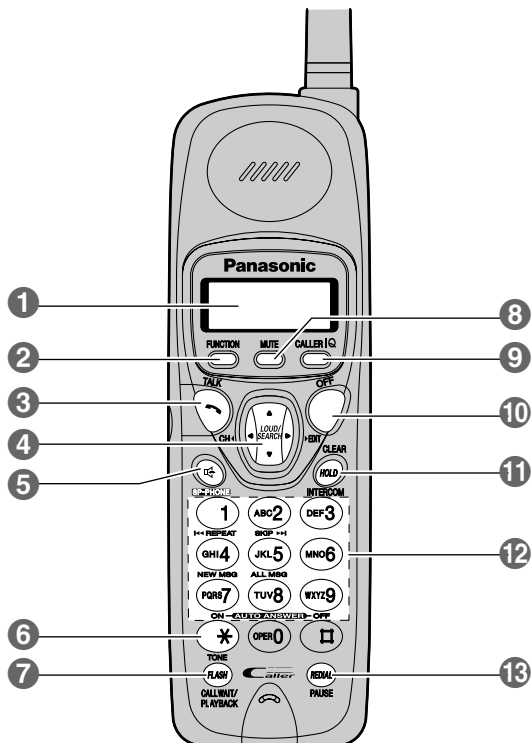

1 Backlit LCD Display

- The lighted display will stay on for a few seconds after pressing a handset button or lifting the handset off the base unit.

2 [FUNCTION]

- To enter programming (page 36, 37, 41).

3 [TALK]

- To make/answer calls (page 35, 37).

4 [LOUD/SEARCH][CH][EDIT]

- To adjust volume (page 29).
- To adjust LCD contrast (page 36).
- To search for a stored name (page 47).
- To view caller information (page 50).
- To select a clear channel (page 35).
- To edit the caller's phone number (page 50).

5 [SP-PHONE]

- For speakerphone operation (page 35, 37).

6 [TONE]

- To change from pulse to tone temporarily during dialing when your line has rotary pulse services.

7 [FLASH][CALL WAIT/PLAYBACK]

- To access special telephone services such as Call Waiting (page 49) or for transferring extension calls.
- To listen to recorded messages (page 76).

8 [MUTE]

- To mute your voice to the other party during a conversation. To release the mute, press [MUTE], [TALK] or [SP-PHONE].

9 [CALLER IQ]

- To use the Caller IQ feature (page 112).

10 [OFF]

- To hang up (page 35, 37).
- To stop viewing caller information (page 50).

11 [CLEAR][HOLD][INTERCOM]

- To erase caller information (page 52).
- To erase an entry (page 45).
- To put a call on hold (page 35).
- To page the base unit (page 39).

12 Dial keypad

- Dial 1: To repeat the recorded messages (page 76).
- Dial 2: To skip the recorded messages (page 76).
- Dial 4: To play new recorded messages (page 76).
- Dial 5: To play all recorded messages (page 76).
- Dial 7: To turn the auto answer setting on (page 76).
- Dial 9: To turn the auto answer setting off (page 76).

13 [REDIAL][PAUSE]

- To redial the last number dialed from the handset.
- To insert a pause during dialing.

Setting (Base Unit)

Ink film

- 1** Open the front cover by pulling up the center part.

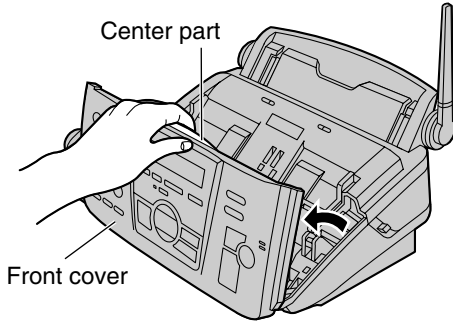

- 2** Release the back cover by pushing the back cover open button (green) on the right side of the unit.
OR
Release the back cover by pushing the back cover open lever (green) in the unit.

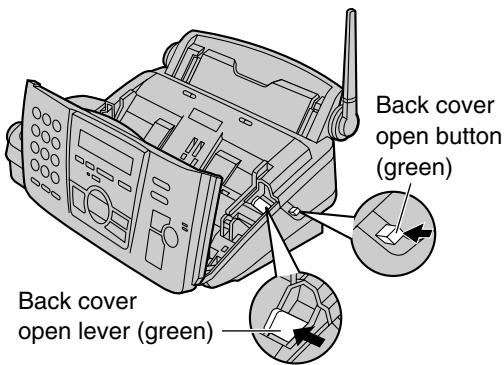

- 3** Open the back cover.

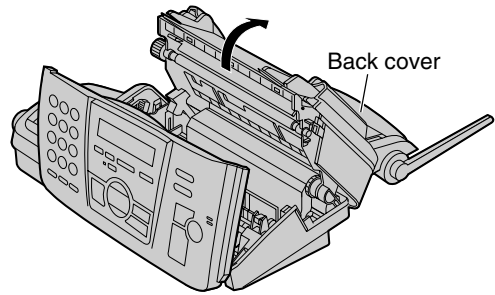

- 4** Insert the blue core of the front ink film roll into the right slot of the unit (①). Insert the "T" shaped gear (blue) into the left slot of the unit (②).
Insert the rear ink film roll (③).
● The ink film is safe to touch, and will not rub off on your hands like carbon paper.

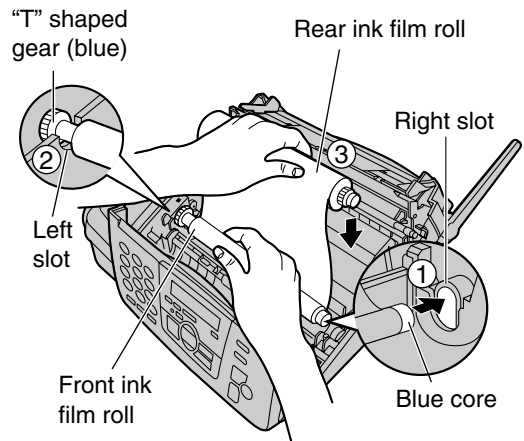

Setting (Base Unit)

- 5** Turn the “T” shaped gear (blue) in the direction of the arrow.

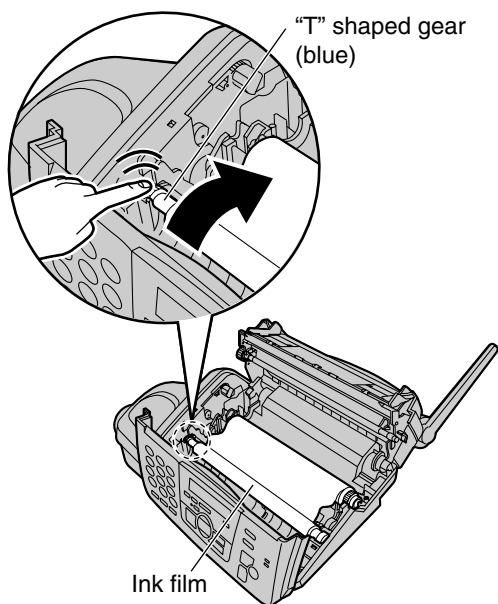

- Make sure that the ink film is wrapped around the blue core at least once.

Correct

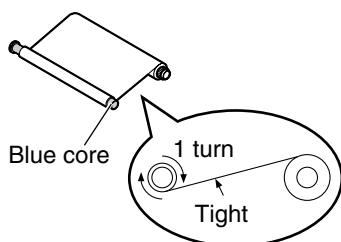

Incorrect

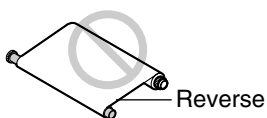
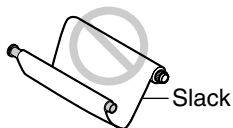
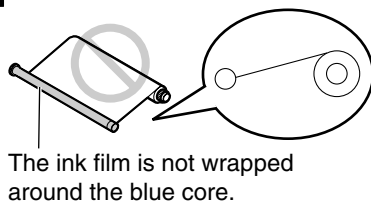

- 6** Close the back cover securely by pushing down on the dotted area at both ends (①). Close the front cover securely (②).
- When the power cord is connected, the following message will be displayed while the unit is checking that there is no slack in the ink film.

PLEASE WAIT

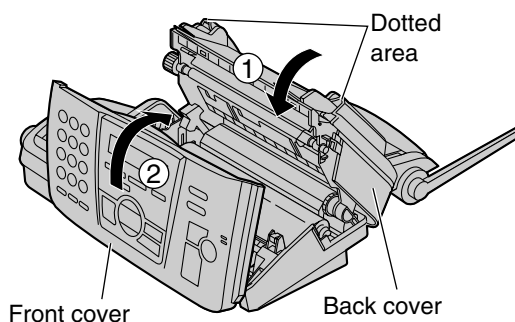

Setting (Base Unit)

Paper tray

The included paper tray is for letter size recording paper.

Insert the tab on the paper tray into the slot on the back of the unit.

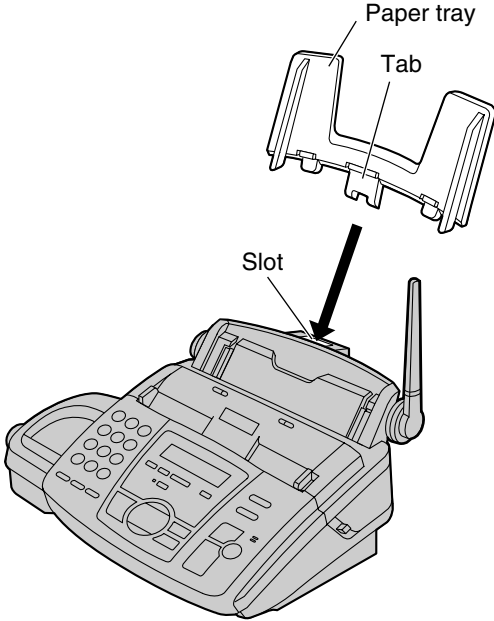

Note:

- Do not place the unit in an area where the paper tray may be obstructed (i.e. by a wall etc.).

To use legal size paper

- Please purchase a legal paper tray, Model No. KX-FA51 (page 10) and install it.



To use A4 size paper

You need to install the A4 paper guide to the right side of the paper tray.

- Change the recording paper size (feature #16, page 88).
1. Insert the bottom tab on the A4 paper guide into the lower slot.
 2. Press the guide into the upper slot.

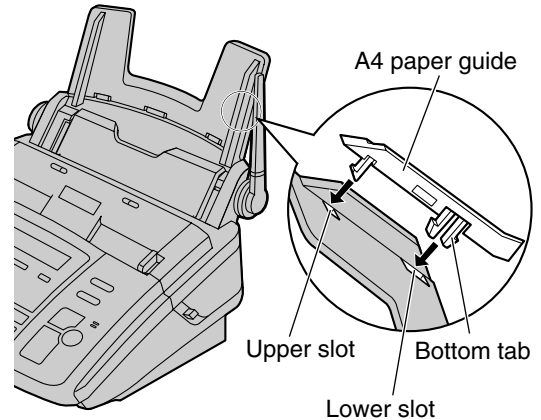

Metal recording paper guide

Attach the metal recording paper guide into the slots on the recording paper exit.

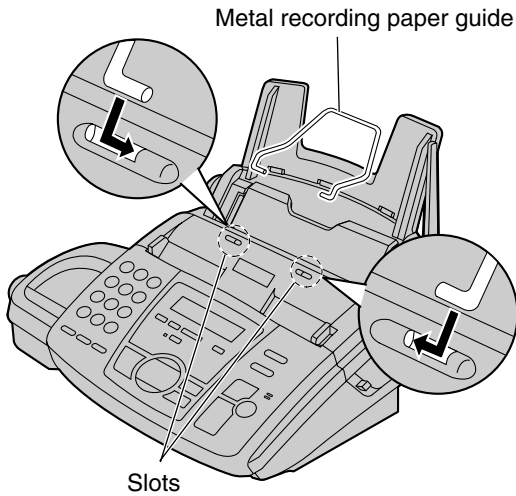

- The recording paper will be ejected from the top of the unit after printing. The metal recording paper guide prevents the printed paper from curling.

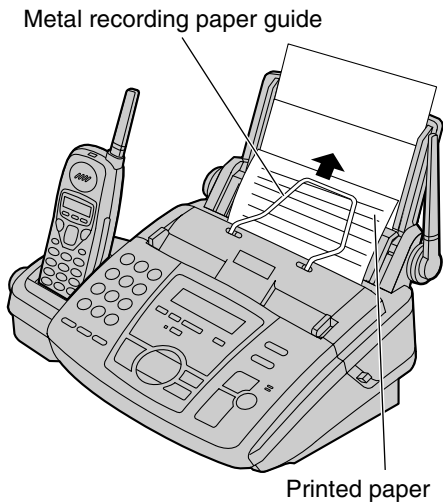

Setting (Base Unit)

Recording paper

Letter, legal or A4 size recording paper can be loaded. The unit can hold up to 50 sheets of 75 g/m² (20 lb.) paper. You may use 60 g/m² to 90 g/m² (16 lb. to 24 lb.) paper. See the note for paper specifications (page 120). **For superior results, we recommend Hammermill® Jet Print paper.** If you use legal size paper, please install a legal paper tray (page 16).

- 1 Fan the stack of paper to prevent a paper jam.



- 2 Pull the tension plate forward and hold open while inserting the paper.

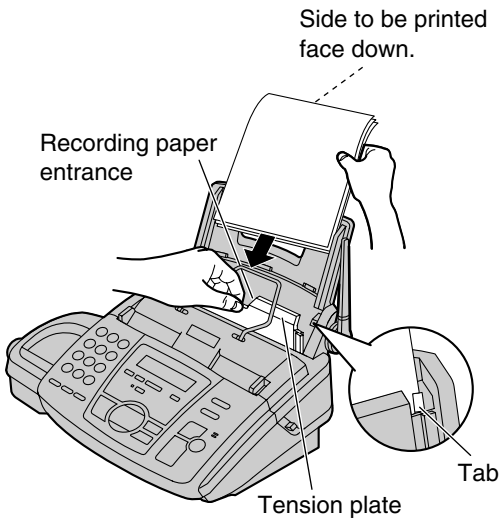

- The paper should not be over the tab.
- If the paper is not inserted correctly, readjust the paper, or the paper may jam.

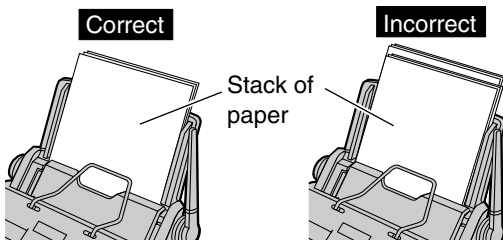

To add paper

1. Pull the tension plate forward and hold open while removing all of the installed paper.
2. Add paper to the stack of paper you removed and straighten.
3. Fan the stack of paper.
4. Pull the tension plate forward and hold open while inserting the paper.

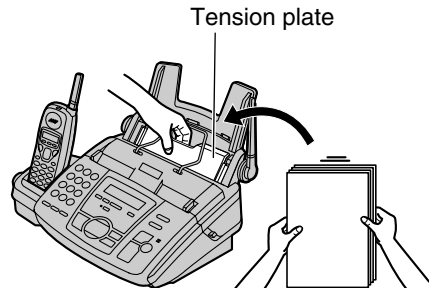

Belt clip and headset

Belt clip

To install the belt clip

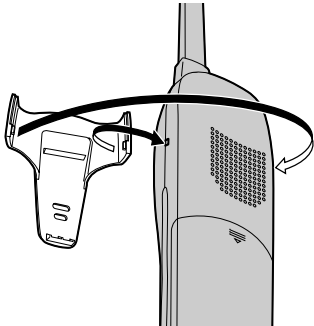

To remove the belt clip



Headset (optional)

Plugging the headset into the handset allows a hands-free telephone conversation. Please use the Panasonic headset Model No. KX-TCA88 or KX-TCA90. See page 10 for accessory information.

To connect the headset

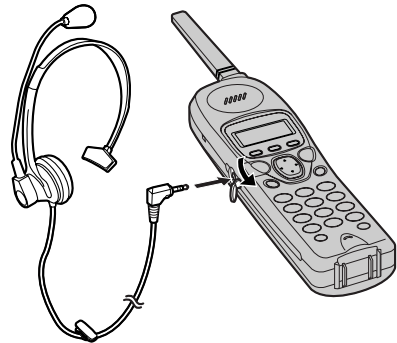

The pictured headset is KX-TCA88.

Connections and Setup

Selecting the way to use your fax machine

You may already have other devices such as a telephone or computer in addition to the fax machine. You may use them in the same room or a different room. Depending on your situation, select the way you prefer to use your fax machine.

- **Case 1:** Using the fax machine only (page 22)
- **Case 2:** Using the fax machine with an extension telephone (page 24)
- **Case 3:** Using the fax machine with a computer (page 26)

Connecting to a telephone line jack and power outlet

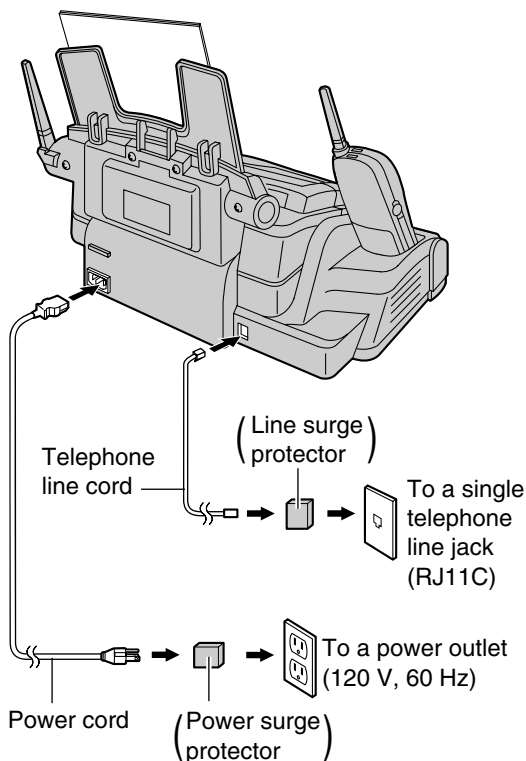

To use surge protectors

- The warranty does not cover damage due to power line surges or lightning. For additional equipment protection, we recommend the use of a surge protector. The following types are available: TELESPIKE BLOK MODEL TSB (TRIPPE MFG. CO.), SPIKE BLOK MODEL SK6-0 (TRIPPE MFG. CO.), SUPER MAX (PANAMAX) or MP1 (ITW LINX).

Caution:

- **When you operate this product, the power outlet should be near the product and easily accessible.**

Note:

- If any other device is connected on the same line, this unit may disturb the network condition of the device.

Battery charge

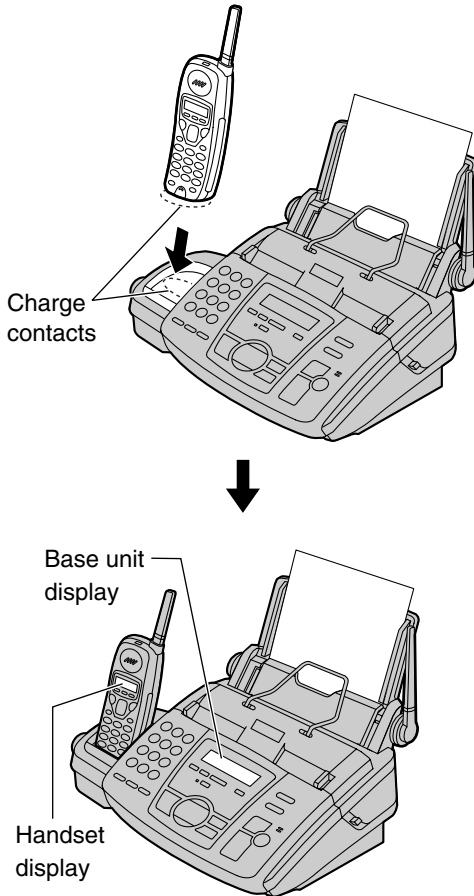

Place the handset on the cradle of the base unit for about **15 hours** before initial use.

- A beep will sound, and the following will be displayed for an instant on the base unit.

Base unit display: CHARGING

The display will show the date and time.

- If the base unit is in use, a beep may not sound and the message may not be shown.

Note:

- Clean the handset and the base unit charge contacts with a dry cloth once a month, or the battery may not charge properly.
- The battery cannot be overcharged.

Battery strength

You can check the battery strength on the handset display.

Handset display	Battery strength
[■■■■]	Fully charged
[■■■]	Medium
[■■]	Low
⚡ [■■] ⚡ (flashing)	Needs to be recharged.

Battery life

If your Panasonic battery is fully charged;

- the battery life will last up to 5 hours while in use (in conversation).
- it will last for up to about 11 days while not in use (off the base unit).
- Battery life may vary depending on usage conditions and ambient temperature.

Recharge

Recharge the battery when:

- the handset beeps intermittently while it is in use, or
- the following is shown and “[■■]” flashes on the handset display.

Handset display: Recharge
⚡ [■■] ⚡

- Recharge the handset battery for more than 15 minutes, or the display will continue showing the indication.

Automatic security code setting

The security code helps to avoid unauthorized use of your telephone line by another cordless telephone. Whenever you place the handset on the base unit, the unit will automatically select one of more than a million security codes.

Connections and Setup

Case 1: Using the fax machine only

Telephone wiring image in house or office

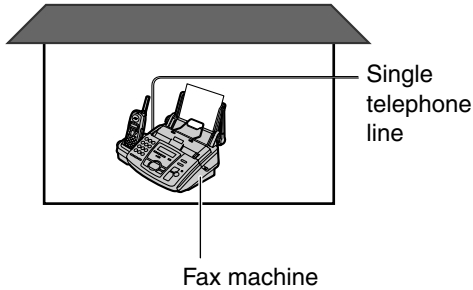

When you are IN the house or office

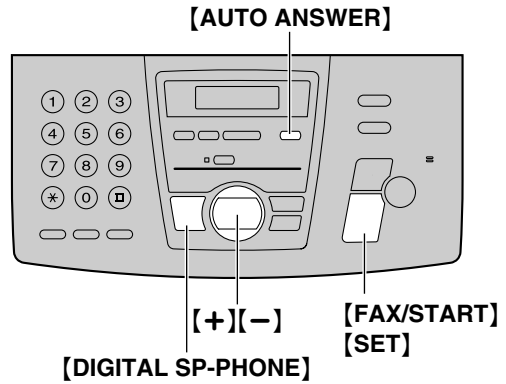

Connections

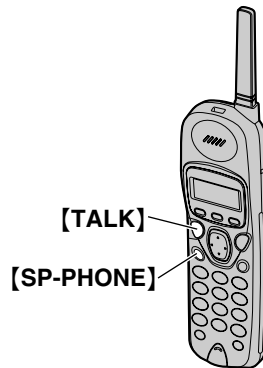
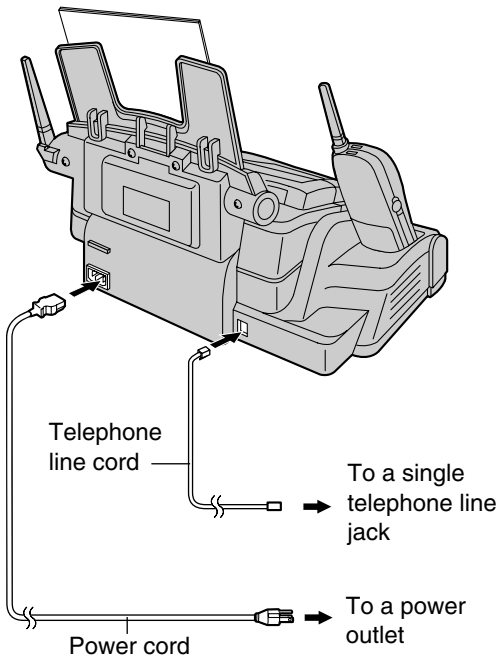

How to set up

Set the fax machine to TEL mode by pressing **[AUTO ANSWER]** until the following is displayed.

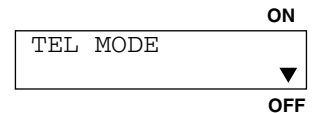

How to receive calls with the base unit

- 1 When the fax machine rings, press **[DIGITAL SP-PHONE]** on the base unit, or lift the handset and press **[TALK]** or **[SP-PHONE]** on the handset.
- 2 If document reception is required, a fax calling tone (slow beep) is heard, or no sound is heard, press **[FAX/START]**.
 - The fax machine will start fax reception.

How to receive calls with the handset

- 1 When the fax machine rings, lift the handset and press **[TALK]** or **[SP-PHONE]**.
- 2 When document reception is required, a fax calling tone (slow beep) is heard, or no sound is heard, press **[*][#][9]** (pre-selected fax activation code) **firmly**.
 - A single beep will be heard.
 - The fax machine will start fax reception.

Note:

- To receive fax documents using the handset, you must set the remote fax activation to on (feature #41, page 90) beforehand.
- You can change the fax activation code in feature #41 (page 90).

When you are OUT of the house or office

How to set up

- 1 Set feature #77 to TAD/FAX mode (page 92) beforehand.
- 2 Press **[AUTO ANSWER]** until the following is displayed.

	ON
TAD/FAX MODE ▲	
2 RINGS	
	OFF

- The display will show the number of rings before the unit answers a call in TAD/FAX mode.
- If necessary, press **[+]** or **[-]** to select the desired ring setting and press **[SET]**.

How to receive calls

If the call is a phone call, the fax machine will record a voice message automatically.

If a fax calling tone is detected, the fax machine will receive a fax automatically.

Note:

- Do not connect an answering machine to the same telephone line. If connected, set automatic answer feature to off.
- Do not subscribe to Voice Mail service.
- If you have already subscribed to Distinctive Ring service, refer to page 66.
- If the fax machine is used only for fax reception, refer to page 64.

Connections and Setup

Case 2: Using the fax machine with an extension telephone

Telephone wiring image in house or office

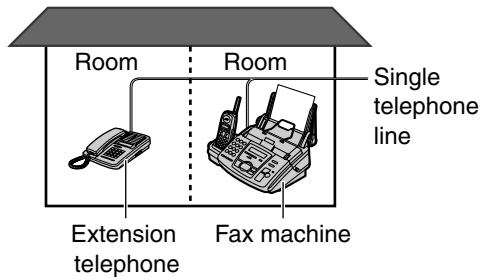

When you are IN the house or office

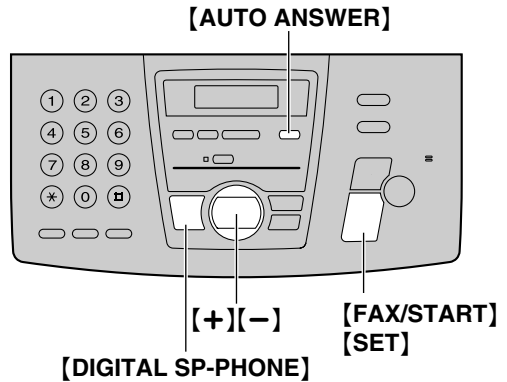

Connections

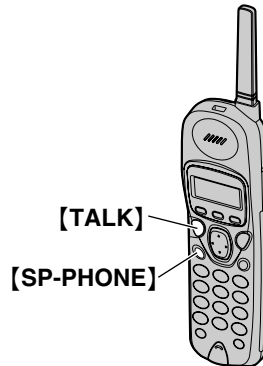
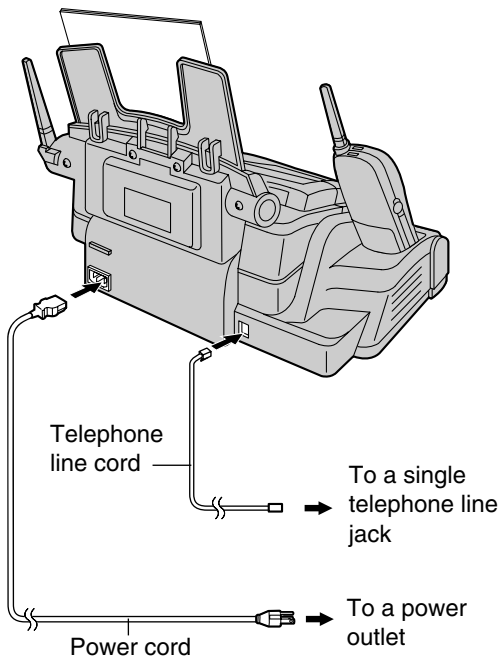

How to set up

Set the fax machine to TEL mode by pressing **[AUTO ANSWER]** until the following is displayed.

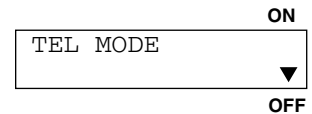

How to receive calls with the base unit

- 1 When the fax machine rings, press **[DIGITAL SP-PHONE]** on the base unit, or lift the handset and press **[TALK]** or **[SP-PHONE]** on the handset.
- 2 If document reception is required, a fax calling tone (slow beep) is heard, or no sound is heard, press **[FAX/START]**.
 - The fax machine will start fax reception.

How to receive calls with the handset

- 1 When the fax machine rings, lift the handset and press **[TALK]** or **[SP-PHONE]**.
- 2 When document reception is required, a fax calling tone (slow beep) is heard, or no sound is heard, press **[*][#][9]** (pre-selected fax activation code) **firmly**.
 - A single beep will be heard.
 - The fax machine will start fax reception.

Note:

- To receive fax documents using the handset, you must set the remote fax activation to on (feature #41, page 90) beforehand.
- You can change the fax activation code in feature #41 (page 90).

How to receive calls with an extension telephone

- 1 When the extension telephone rings, lift the handset of the extension telephone.
- 2 When document reception is required, a fax calling tone (slow beep) is heard, or no sound is heard, press **[*][#][9]** (pre-selected fax activation code) **firmly**.
- 3 Replace the handset.
 - The fax machine will start fax reception.

Note:

- To receive fax documents using the extension telephone, you must set the remote fax activation to on (feature #41, page 90) beforehand.
- You can change the fax activation code in feature #41 (page 90).

When you are OUT of the house or office

How to set up

- 1 Set feature #77 to TAD/FAX mode (page 92) beforehand.
- 2 Press **[AUTO ANSWER]** until the following is displayed.



- The display will show the number of rings before the unit answers a call in TAD/FAX mode.
- If necessary, press **[+]** or **[-]** to select the desired ring setting and press **[SET]**.

How to receive calls

If the call is a phone call, the fax machine will record a voice message automatically. If a fax calling tone is detected, the fax machine will receive a fax automatically.

Note:

- Do not connect an answering machine to the same telephone line. If connected, set automatic answer feature to off.
- Do not subscribe to Voice Mail service.
- If you have already subscribed to Distinctive Ring service, refer to page 66.
- If the fax machine is used only for fax reception, refer to page 64.

Connections and Setup

Case 3: Using the fax machine with a computer

Telephone wiring image in house or office

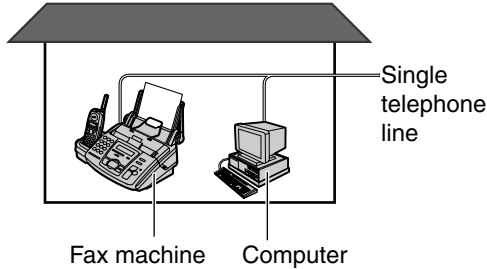

Note:

- If you are subscribed to the ADSL service, fax transmission/reception may be disturbed, or you may hear interference noise during telephone conversation. A filter to prevent this is provided from your service company. Please attach the filter to the telephone line cord of the fax machine.

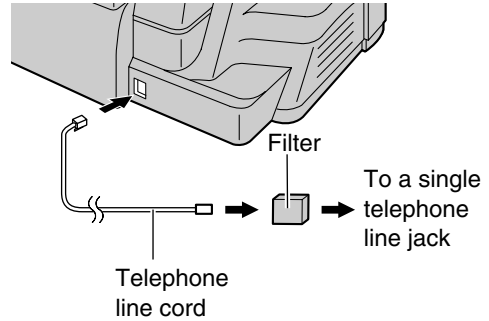

Connections

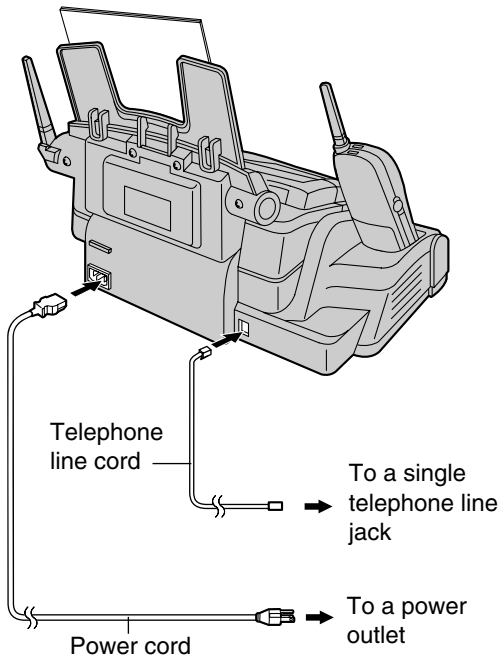

When you are IN the house or office

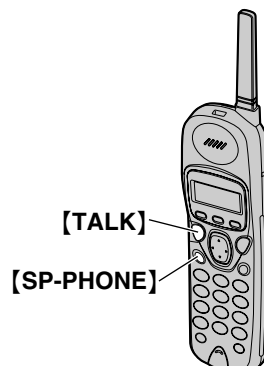
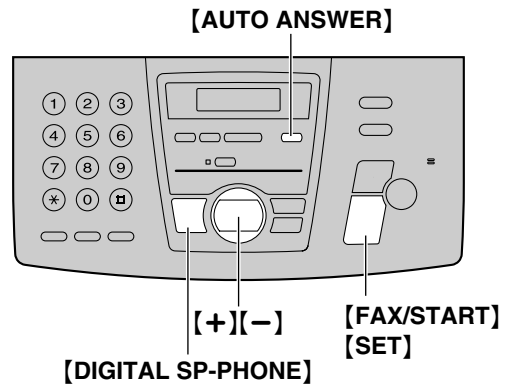

How to set up

Set the fax machine to TEL mode by pressing **[AUTO ANSWER]** until the following is displayed.

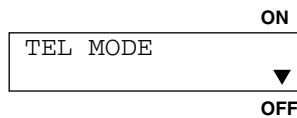

How to receive calls with the base unit

- 1 When the fax machine rings, press **[DIGITAL SP-PHONE]** on the base unit, or lift the handset and press **[TALK]** or **[SP-PHONE]** on the handset.
- 2 If document reception is required, a fax calling tone (slow beep) is heard, or no sound is heard, press **[FAX/START]**.
 - The fax machine will start fax reception.

How to receive calls with the handset

- 1 When the fax machine rings, lift the handset and press **[TALK]** or **[SP-PHONE]**.
- 2 When document reception is required, a fax calling tone (slow beep) is heard, or no sound is heard, press **[*][#][9]** (pre-selected fax activation code) **firmly**.
 - A single beep will be heard.
 - The fax machine will start fax reception.

Note:

- To receive fax documents using the handset, you must set the remote fax activation to on (feature #41, page 90) beforehand.
- You can change the fax activation code in feature #41 (page 90).

When you are OUT of the house or office

How to set up

- 1 Set feature #77 to TAD/FAX mode (page 92) beforehand.
- 2 Press **[AUTO ANSWER]** until the following is displayed.



- The display will show the number of rings before the unit answers a call in TAD/FAX mode.
- If necessary, press **[+]** or **[-]** to select the desired ring setting and press **[SET]**.

How to receive calls

If the call is a phone call, the fax machine will record a voice message automatically. If a fax calling tone is detected, the fax machine will receive a fax automatically.

Note:

- Do not connect an answering machine to the same telephone line. If connected, set automatic answer feature to off.
- Do not subscribe to Voice Mail service.
- If you have already subscribed to Distinctive Ring service, refer to page 66.
- If the fax machine is used only for fax reception, refer to page 64.

Help Button

Help function

You can print a quick reference for assistance as follows.

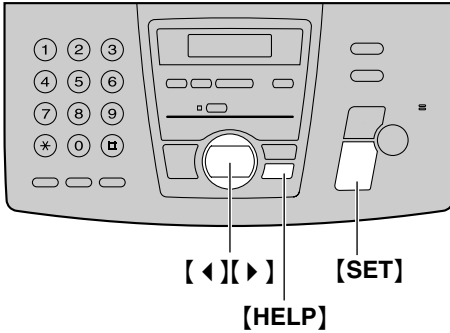

1 Press **[HELP]**.

PRESS NAVI. [◀ ▶]
& SET

2 Press **[◀]** or **[▶]** until the desired item is displayed.

1. How to send faxes with the voice guide.

SEND GUIDE
PRESS SET

2. How to set the date, time, your logo and fax number.

QUICK SET UP
PRESS SET

3. How to program the features.

FEATURE LIST
PRESS SET

4. How to store names and telephone numbers in the directory and how to dial them.

DIRECTORY
PRESS SET

5. Help with problems operating the answering device.

TAD OPERATION
PRESS SET

6. Help with problems sending/receiving faxes.

FAX SND/RCV
PRESS SET

7. How to use the copier function.

COPIER
PRESS SET

8. Frequently asked questions and answers.

Q and A
PRESS SET

9. Explanation of error messages shown on the display.

ERRORS
PRESS SET

10. List of available reports.

REPORTS
PRESS SET

11. How to use the Caller ID service.

CALLER ID
PRESS SET

3 Press **[SET]**.

PRINTING

Adjusting handset volume

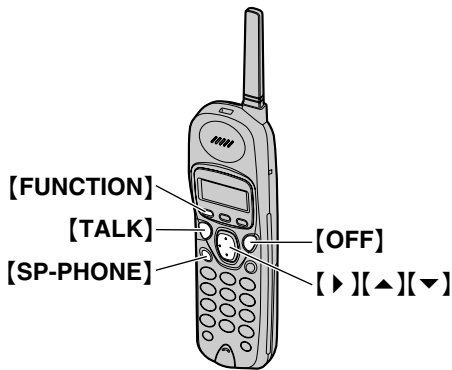

Ringer volume

3 levels (high/low/off) are available.
Make sure the handset is idle.

- 1 Press [FUNCTION].
- 2 Press [▲] or [▼] repeatedly until the arrow points to "Ringer volume".

```
Save directory
▶Ringer volume
Ringer pattern
```

- 3 Press [▶].
- 4 Press [▲] or [▼] to select the desired volume.
 - The current ringer will sound.
- 5 Press [▶].

To turn the ringer off:

1. Press [FUNCTION].
2. Press [▲] or [▼] repeatedly until the arrow points to "Ringer volume".

```
Save directory
▶Ringer volume
Ringer pattern
```

3. Press [▶].
4. Press [▼] repeatedly until the following is displayed and press [▶].

```
Ringer off
▼▲ ▶=Save
```

To turn the ringer back on, press [▲] or [▼].

5. Press [▶].

While the ringer volume is set to off:

When a call is received, the handset will not ring.

Ringer pattern

- You can select one of six ringer patterns.

1. Press [FUNCTION].
2. Press [▼] or [▲] repeatedly until the arrow points to "Ringer pattern".

```
Ringer volume
▶Ringer pattern
Program
```

3. Press [▶].
4. Press [▼] or [▲] to select the desired ringer pattern.
5. Press [▶].
6. Press [OFF].

Handset receiver volume

3 levels (high/middle/low) are available.
While using [TALK], press [▲] or [▼].

Speaker volume

6 levels (high to low) are available.
While using the [SP-PHONE], press [▲] or [▼].

Note:

- When you replace the battery, the selected volume setting will return to the default setting. Reprogram if necessary.

Volume

Adjusting base unit volume

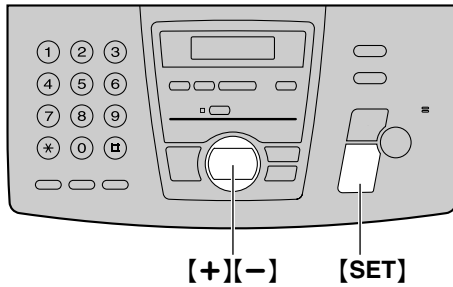

Fax voice guidance volume

9 levels (high to off) are available.

While listening to the fax voice guidance, press **[+] or **[-]**.**

Answering device volume

9 levels (high to off) are available.

While listening to the recorded messages, press **[+] or **[-]**.**

Ringer volume

4 levels (high/middle/low/off) are available.

While the unit is idle, press **[+] or **[-]**.**

- If any documents are in the document entrance, you cannot adjust the ringer volume. Confirm that there are no documents in the entrance.

To turn the ringer off:

- 1** Press **[-]** repeatedly until the following is displayed.

RINGER OFF= OK?
YES : SET/NO : STOP

- 2** Press **[SET]**.

RINGER OFF

- To turn the ringer back on, press **[+]**.

While the ringer volume is set to off:

When a call is received, the unit will not ring and will display the following.

INCOMING CALL

Ringer pattern

- You can select one of three ringer patterns. Change the setting (feature #17, page 88). The ringer pattern you selected will sound when the unit receives a call.

Speaker volume

8 levels (high to low) are available.

While using the speakerphone, press **[+] or **[-]**.**

Date and time, your logo and fax number

You should program the date and time, your logo and fax number. This information will be printed on each page transmitted from your unit.

Setting the date and time

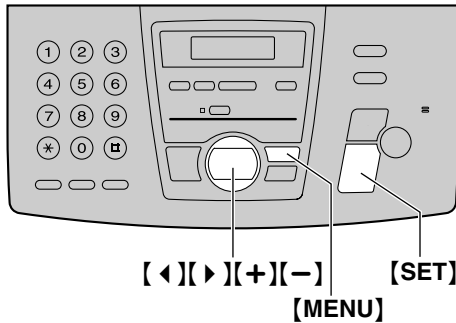

- 1 Press **[MENU]**.

```
SYSTEM SET UP  
PRESS NAVI. [◀ ▶]
```

- 2 Press **[◀]** or **[▶]** until the following is displayed.

```
SET DATE & TIME  
PRESS SET
```

- 3 Press **[SET]**.
 - Cursor (■) will appear on the display.

```
M: 01/D: 01/Y: 02  
TIME: 12:00AM
```

- 4 Enter the correct month/day/year by selecting 2 digits for each, using the dial keypad.

Example: August 10, 2002

Press **[0][8][1][0][0][2]**.

```
M: 08/D: 10/Y: 02  
TIME: 12:00AM
```

- 5 Enter the correct hour/minute by selecting 2 digits for each, using the dial keypad. Press **[*]** to select "AM" or "PM".

Example: 10:15PM (12 hour clock entry)

1. Press **[1][0][1][5]**.

```
M: 08/D: 10/Y: 02  
TIME: 10:15AM
```

2. Press **[*]** until "PM" is displayed.

```
M: 08/D: 10/Y: 02  
TIME: 10:15PM
```

- 6 Press **[SET]**.
 - The next feature will be displayed.

- 7 Press **[MENU]**.

Note:

- You can enter the number by pressing **[+]** or **[-]** in steps 4 and 5. In this case, press **[▶]** to move the cursor.
- The accuracy of the clock is approximately ± 60 seconds a month.

To correct a mistake

Press **[◀]** or **[▶]** to move the cursor to the incorrect number, and make the correction.

If you have registered with openLCR service

The date and time will be automatically set. Do not change the date and time setting yourself.

Initial Programming

Setting your logo

The logo can be your company, division or name.

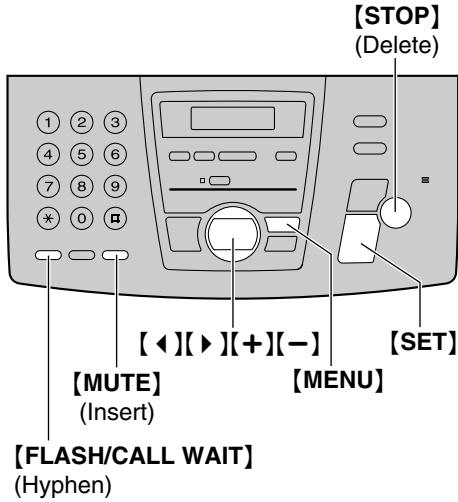

1 Press **[MENU]**.

SYSTEM SET UP
PRESS NAVI. [◀ ▶]

2 Press **[◀]** or **[▶]** until the following is displayed.

YOUR LOGO
PRESS SET

3 Press **[SET]**.

LOGO=

4 Enter your logo, up to 30 characters, using the dial keypad. See page 33 for details.
Example: "BILL"

1. Press **[2]** 2 times.
 - Cursor (|) will appear on the display.

LOGO=B|

2. Press **[4]** 3 times.

LOGO=BI|

3. Press **[5]** 3 times.

LOGO=BIL|

4. Press **[▶]** to move the cursor to the next space and press **[5]** 3 times.

LOGO=BILL|

- 5** Press **[SET]**.
 - The next feature will be displayed.

6 Press **[MENU]**.

Note:

- You can enter your logo by pressing **[+]** or **[-]** in step 4. In this case, press **[▶]** to move the cursor (see page 33 for details).

To change capital or lower-case letters

Pressing the **[#]** key will change to capital or lower-case alternately.

1. Press **[2]** 2 times.

LOGO=B

2. Press **[4]** 3 times.

LOGO=BI

3. Press **[#]**.

LOGO=Bi

4. Press **[5]** 3 times.

LOGO=Bill

To correct a mistake

Press **[◀]** or **[▶]** to move the cursor to the incorrect character, and make the correction.

To delete a character

Press **[◀]** or **[▶]** to move the cursor to the character you want to delete and press **[STOP]**.

To insert a character

1. Press **[◀]** or **[▶]** to move the cursor to the position to the right of where you want to insert the character.
2. Press **[MUTE]** to insert a space and enter the character.

To select characters with the dial keypad

Pressing the dial keys will select a character as shown below.

Keys	Characters
[1]	1 [] { } + - / = , . _ ` : ; ?
[2]	A B C a b c 2
[3]	D E F d e f 3
[4]	G H I g h i 4
[5]	J K L j k l 5
[6]	M N O m n o 6
[7]	P Q R S p q r s 7
[8]	T U V t u v 8
[9]	W X Y Z w x y z 9
[0]	0 () < > ! " # \$ % & ¥ * @ ^ ' →
[⇄]	To change capital or lower-case letter.
[FLASH/ CALL WAIT]	Hyphen button (To insert a hyphen.)
[MUTE]	Insert button (To insert one character or one space.)
[STOP]	Delete button (To delete a character.)
[▶]	The cursor is moved to the right. To enter another character using the same number key, move the cursor to the next space.
[◀]	The cursor is moved to the left.

To select characters using **[+]** or **[-]**

Instead of pressing the dial keys, you can select characters using **[+]** or **[-]**.

1. Press **[+]** or **[-]** until the desired character is displayed.
2. Press **[▶]** to move the cursor to the next space.
 - The character displayed in step 1 is inserted.
3. Return to step 1 to enter the next character.

Display order of characters

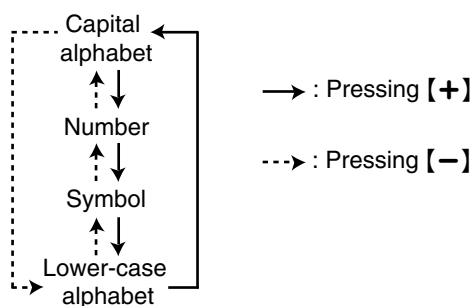

Initial Programming

Setting your fax number

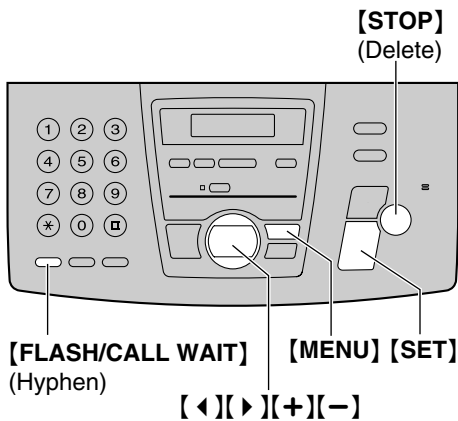

To delete a number

Press [◀] or [▶] to move the cursor to the number you want to delete and press [STOP].

1 Press [MENU].

SYSTEM SET UP
PRESS NAVI. [◀ ▶]

2 Press [◀] or [▶] until the following is displayed.

YOUR FAX NO.
PRESS SET

3 Press [SET].

NO. =

4 Enter your fax number, up to 20 digits, using the dial keypad.

Example: NO. =1234567

5 Press [SET].

- The next feature will be displayed.

6 Press [MENU].

Note:

- You can enter your fax number by pressing [+] or [-] in step 4. In this case, press [▶] to move the cursor.
- The [*] button replaces the digit with a "+" and the [#] button replaces it with a space.
Example: +234 5678
Press [*][2][3][4][#][5][6][7][8].
- To enter a hyphen in a telephone number, press [FLASH/CALL WAIT].

To correct a mistake

Press [◀] or [▶] to move the cursor to the incorrect number, and make the correction.

Making and Answering Calls

Phone calls - making

With the handset

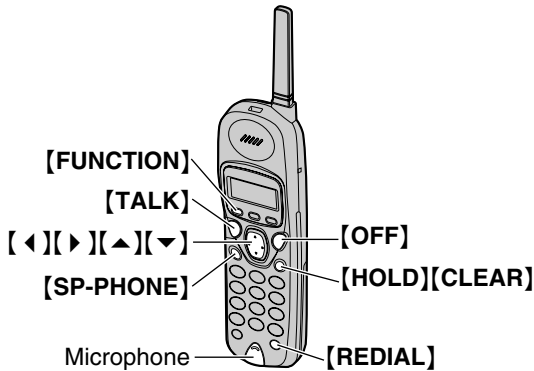

1 Lift the handset and press **[TALK]**.

2 Dial the telephone number.

Example:

Talk
1112222

- If noise interferes with the conversation, press **[◀]** to select a clear channel or move closer to the base unit.

3 When finished talking, press **[OFF]** or place the handset on the base unit.

Note:

- If short beeps sound when you press **[TALK]**;
 - move closer to the base unit, or
 - place the handset on the base unit.Then try again.
- You can switch to the hands-free phone conversation by pressing **[SP-PHONE]**. To switch back, press **[TALK]**.
- During a conversation using the handset, the call can be switched to the base unit speakerphone by pressing **[DIGITAL SP-PHONE]** on the base unit.

Making hands-free phone calls

1. Lift the handset and press **[SP-PHONE]**.

2. Dial the telephone number.

Example:

SP-phone
3334444

3. When the other party answers, talk into the microphone.

4. When finished talking, press **[OFF]** or place the handset on the base unit.

To put a call on hold

Press **[HOLD]**.

To release the hold, press **[TALK]** or **[SP-PHONE]** on the handset or **[DIGITAL SP-PHONE]** on the base unit.

- If you do not press a button for more than 6 minutes, a beep will sound.
- If you do not press a button for more than 10 minutes, the line will be disconnected.

To redial the last number

Press **[TALK]** or **[SP-PHONE]** and press **[REDIAL]**.

To redial using the redial list (Memory redial)

The last 5 phone numbers dialed with the handset are stored in the redial list.

1. Press **[REDIAL]**.

- The last number dialed is displayed.

Example:

3334444
▼▲Redial list

2. Scroll to the desired number by pressing **[▼]** or **[▲]**.

- You can also scroll through the list by pressing **[REDIAL]**.
- To delete the displayed number, press **[CLEAR]**.
- To exit the list, press **[OFF]**.

3. Press **[TALK]** or **[SP-PHONE]**.

Note:

- If the list is empty, the following is displayed in step 1.

No items stored

Making and Answering Calls

Adjusting LCD contrast

5 levels (high to low) are available.

Make sure the handset is idle.

1. Press **[FUNCTION]**.

```
-----  
▶Save directory  
Ringer volume
```

2. Press **[▲]** or **[▼]** until the arrow points to "Program".

```
Ringer pattern  
▶Program  
-----
```

3. Press **[▶]**.

4. Press **[▲]** or **[▼]** until the arrow points to "LCD contrast".

```
Talk switching  
▶LCD contrast  
-----
```

5. Press **[▶]**.

```
LCD contrast  
Low ████ High  
▼▲ ▶=Save
```

6. Press **[▲]** or **[▼]** to select the desired contrast.

7. Press **[▶]**.

- The current contrast will be displayed.

8. Press **[OFF]** to exit the program.

With the base unit

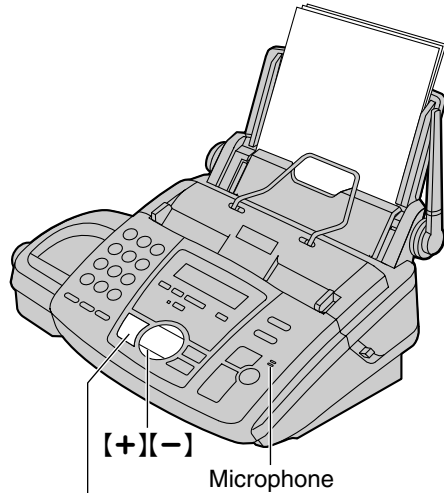

[DIGITAL SP-PHONE]

- 1 Press **[DIGITAL SP-PHONE]**.

```
TEL=  
PRESS NAVI. [ ▶]
```

- 2 Dial the telephone number.

- When the other party answers, talk into the microphone.

- 3 When finished talking, press **[DIGITAL SP-PHONE]**.

Note:

- To switch to the handset while using the base unit speakerphone:
 - If the handset is off the base unit, press **[TALK]** or **[SP-PHONE]**.
 - If on the base unit, just lift up.

Speakerphone operation

- Use the speaker in a quiet room.
- Adjust the handset speakerphone volume using **[▲]** or **[▼]**.
- Adjust the base unit speaker volume using **[+]** or **[-]**.

Making and Answering Calls

Phone calls - answering

With the handset

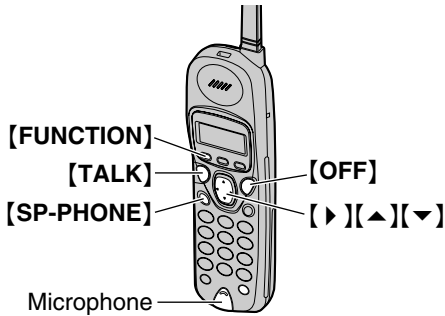

- 1 Lift the handset and press **[TALK]** when the unit rings.
 - You can also answer a call by pressing any dial key 0 to 9, *, or #.
(Any key talk feature)
- 2 When finished talking, press **[OFF]** or place the handset on the base unit.

Auto talk feature (Handset)

You can answer a call by just lifting the handset off the base unit without pressing **[TALK]**. This feature is set to off. To activate this feature, proceed as follows.

1. Press **[FUNCTION]**.
 - Make sure the handset is idle.

```
-----  
▶Save directory  
Ringer volume
```

2. Press **[▲]** or **[▼]** repeatedly until the arrow points to "Program".

```
Ringer pattern  
▶Program  
-----
```

3. Press **[▶]**.

```
-----  
▶Talk switching  
LCD contrast
```

4. Press **[▶]**.

```
Auto talk  
:Off  
▼▲ ▶=Save
```

5. Press **[▲]** or **[▼]** to select "On".

```
Auto talk  
:On  
▼▲ ▶=Save
```

6. Press **[▶]**.
7. Press **[OFF]** to exit the program.

Note:

- If you subscribe to Caller ID service, and want to view the caller's information on the handset display before answering a call, turn off this feature.

Answering phone calls hands-free

1. When the unit rings, lift the handset and press **[SP-PHONE]**, and talk into the microphone.
2. When finished talking, press **[OFF]** or place the handset on the base unit.

With the base unit

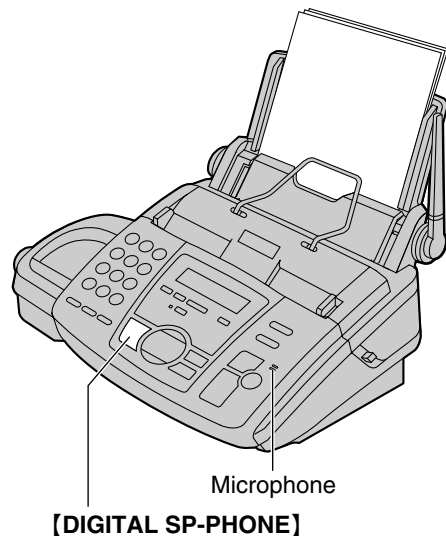

- 1 When the unit rings, press **[DIGITAL SP-PHONE]** and talk into the microphone.
- 2 When finished talking, press **[DIGITAL SP-PHONE]**.

Making and Answering Calls

Intercom

Paging the base unit from the handset

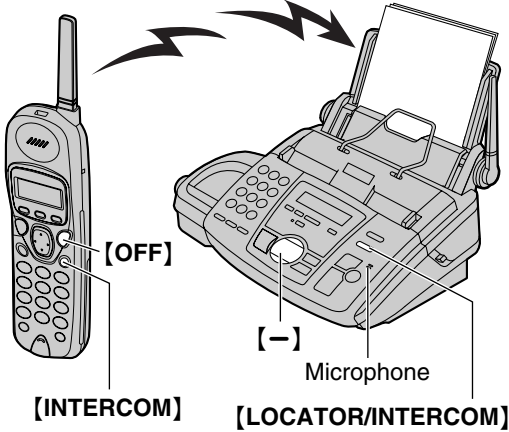

Note:

- If the handset user has difficulty hearing the base unit user, ask the base unit user to decrease the speaker volume by pressing [-].

1 Handset:

Press **[INTERCOM]**.

- The base unit will beep. You can then talk with the base unit user.
- The conversation time will appear on the display.

Handset display:
(Example)

Intercom
00-01-12 []

2 Base unit:

Answer through the microphone.

Base unit display:

PAGING
↓
INTERCOM

3 Handset:

When finished talking, press **[OFF]** or lay the handset on the base unit.

Base unit:

When finished talking, press **[LOCATOR/INTERCOM]**.

Making and Answering Calls

Paging the handset from the base unit

Handset locator

Using this feature, you can locate the handset if it has been misplaced.

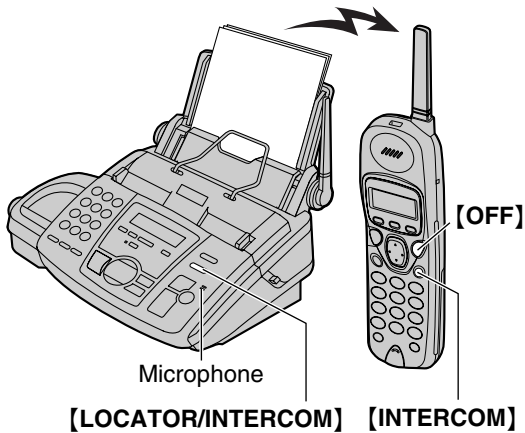

1

Base unit:

Press **[LOCATOR/INTERCOM]**.

- The base unit will page the handset for about 1 minute.

Base unit display:

PAGING

Handset display:

Paging
Press INTERCOM

- To stop paging, press **[LOCATOR/INTERCOM]** again.

2

Handset:

Press **[INTERCOM]** to answer.

Handset display:

Intercom
(Example)
00-01-12 []

3

Base unit:

Speak into the microphone.

Base unit display:

INTERCOM

4

Base unit:

When finished talking, press

[LOCATOR/INTERCOM].

Handset:

When finished talking, press **[OFF]** or place the handset on the base unit.

Making and Answering Calls

Transferring a call

The intercom can be used during a conversation. This feature enables you to transfer an outside call between the handset and the base unit.

From the handset to the base unit

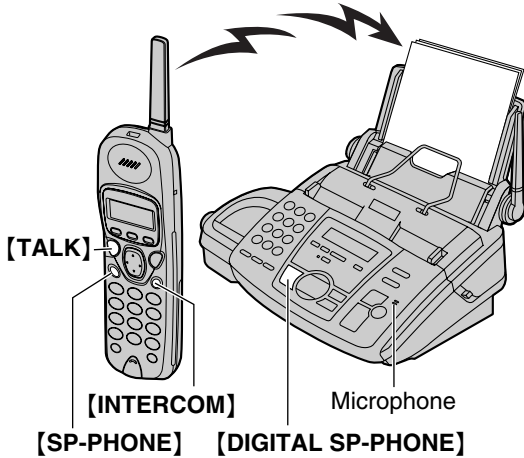

- Handset:**
During an outside call, press **[INTERCOM]** 2 times to page the base unit.
 - The handset user can talk with the base unit user.
 - The outside call will be put on hold.

Handset display:

Intercom hold
00-01-12 []

Base unit display:

PAGING

↓

INTERCOM HOLD

- If there is no answer on the base unit, press **[TALK]** or **[SP-PHONE]** to return to the outside call.

- Base unit:**
Talk with the handset user through the microphone.

- Base unit:**
To answer the outside call, press **[DIGITAL SP-PHONE]**.

From the base unit to the handset

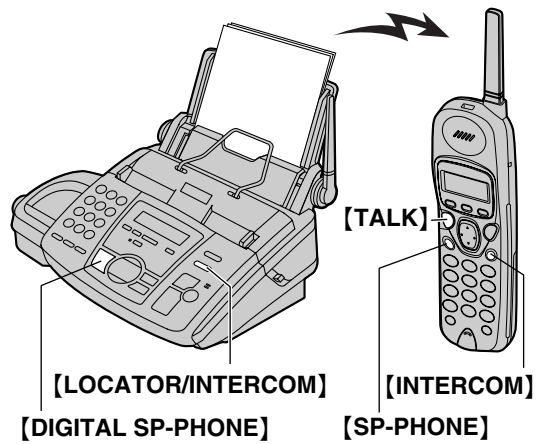

- Base unit:**
During an outside call, press **[LOCATOR/INTERCOM]** to page the handset.
 - The base unit will start paging the handset for 1 minute.
 - The outside call will be put on hold.

Base unit display:

PAGING

Handset display:

Paging
Press INTERCOM

- If there is no answer on the handset, press **[DIGITAL SP-PHONE]** to return to the outside call.

- Handset:**
Press **[INTERCOM]** to answer the page.

Handset display:

Intercom hold
(Example) 00-01-12 []

Base unit display:

INTERCOM HOLD

- Handset:**
To answer the outside call, press **[TALK]** or **[SP-PHONE]**.

Storing names and telephone numbers into the navigator directory

For rapid access to frequently dialed numbers, the unit provides the navigator directory. You can store the names and telephone numbers using both the handset and base unit up to 50 entries in total. First program the entries, then see page 47 to make a phone call.

- You can also send faxes using the navigator directory (page 58).

Using the handset

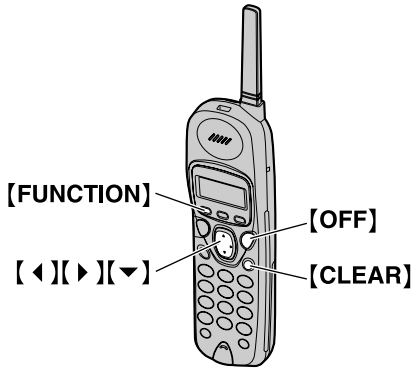

1 Press **[FUNCTION]**.

```
-----
▶Save directory
Ringer volume
```

2 Press **[▶]**.

Example: Directory=
2 items

Enter name
◀▶ ▼=Next

3 Enter the name, up to 10 characters (see the character table).

Example: Enter name
Tom Jones
◀▶ ▼=Next

- Pressing the **[#]** key will change to capital or lower-case alternatively.

4 Press **[▼]**.

Enter phone no.

5 Enter the telephone number, up to 30 digits, using the dial keypad.

Example: 3334444
◀▶ ▼=Next

6 Press **[▼]**.

Example: Tom Jones
3334444
▲=Edit ▶=Save

7 Press **[▶]**.

- To program other entries, repeat steps 2 to 7.

8 Press **[OFF]** to exit the program.

Helpful hint:

- For your convenience, HELP-FAX (1-800-435-7329) has been pre-programmed. If you cannot solve a problem, call using this entry (page 47). If unnecessary, you can erase it (page 45).

Keys	Characters
[1]	1 (Space) [] { } + - / = , . _ ` : ; ?
[2]	A B C a b c 2
[3]	D E F d e f 3
[4]	G H I g h i 4
[5]	J K L j k l 5
[6]	M N O m n o 6
[7]	P Q R S p q r s 7
[8]	T U V t u v 8
[9]	W X Y Z w x y z 9
[0]	0 () < > ! " # \$ % & ¥ * @ ^ ' →

Note:

- To enter another character using the same number key, press **[▶]** to move the cursor to the next space.
- If there is no space to store new entries, the following is displayed.
Erase unnecessary entries (page 45).

Directory full

Navigator Directory

To correct a mistake

1. Press [**◀**] or [**▶**] to move the cursor to the incorrect character.
2. Press [**CLEAR**].
3. Enter the correct character.

Using the base unit

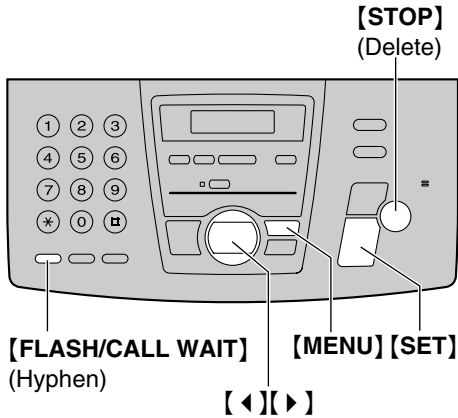

- 1 Press [**MENU**] repeatedly until the following is displayed.

```
DIRECTORY SET
NAVI . =* BROAD=#
```

- 2 Press [*****].

```
NAME=
STORE:PRESS SET
```

- 3 Enter the name, up to 10 characters (see page 33 for instructions).

Example:

```
NAME=ALICE
STORE:PRESS SET
```

- Pressing the [**#**] key will change to capital or lower-case alternatively.

- 4 Press [**SET**].

```
NO. =
```

- 5 Enter the telephone number, up to 30 digits, using the dial keypad.

Example:

```
NO. =5552233
```

- If you want to enter a hyphen, press [**FLASH/CALL WAIT**].

- 6 Press [**SET**].

```
REGISTERED
↓
NAME=
STORE:PRESS SET
```

- To program other entries, repeat steps 3 to 6.

- 7 Press [**MENU**] to exit the program.

Helpful hint:

- You can confirm the stored entries in the telephone number list (page 111).

Note:

- When the following is displayed in step 6, you can store only 5 more entries.

```
REGISTERED
SPACE= 5 DIRS.
```

- If there is no space to store new entries, the following is displayed in step 6. Erase unnecessary entries (page 45).

```
REGISTERED
DIRECTORY FULL
```

- A hyphen or a space entered in a telephone number counts as two digits.

To correct a mistake

Press [**◀**] or [**▶**] to move the cursor to the incorrect character/number, and then make the correction.

To delete a character/number

Press [**◀**] or [**▶**] to move the cursor to the character/number you want to delete, and press [**STOP**].

- If [**STOP**] is pressed before pressing [**◀**] or [**▶**], all characters/numbers will be deleted.

Editing a stored entry

Entries stored in the handset and the base unit are for common use and can be edited from both the handset and the base unit.

Using the handset

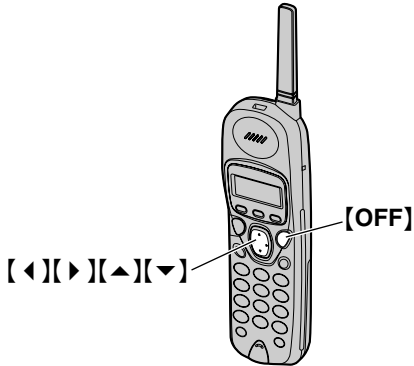

1 Press [**LEFT**] or [**RIGHT**].

```
Directory list
▼▲
▶=Caller's list
```

2 Press [**UP**] or [**DOWN**] until the desired entry is displayed.

Example:

```
Jane
1234567
```

3 Press [**RIGHT**].

Example:

```
Enter name
Jane
◀▶          ▼=Next
```

- If you do not need to edit the name, skip to step 5.

4 Edit the name (see page 41 for instructions).

5 Press [**DOWN**].

Example:

```
1234567
◀▶          ▼=Next
```

- If you do not need to edit the telephone number, skip to step 7.

6 Edit the telephone number. For further details, see page 41.

7 Press [**DOWN**].

Example:

```
Jane
6789453
▲=Edit  ▶=Save
```

8 Press [**RIGHT**].

9 Press [**OFF**] to exit the program.

Using the base unit

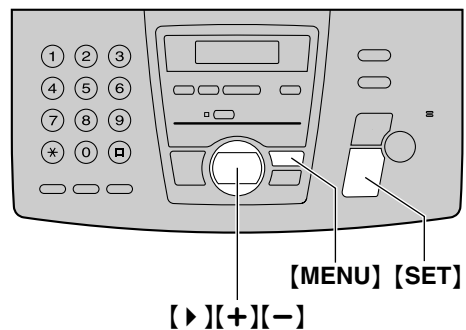

1 Press [**RIGHT**].

- Confirm that there are no documents in the document entrance.

```
DIRECTORY [+ -]
<MAILBOX>▶
```

2 Press [**+**] or [**-**] until the desired entry is displayed.

Example:

```
MARY
0123456
```



```
MARY
EDIT:PRESS MENU
```

3 Press [**MENU**].

Example:

```
NAME=MARY
EDIT=* DELETE=#
```

4 Press [*****].

Example:

```
NAME=MARY
STORE:PRESS SET
```

- If you do not need to edit the name, skip to step 6.

Navigator Directory

5 Edit the name (see page 33, 42 for instructions).

6 Press **[SET]**.

Example:

- If you do not need to edit the telephone number, skip to step 8.

7 Edit the telephone number. For further details, see page 42.

8 Press **[SET]**.

Erasing a stored entry

Once erased, an entry cannot be accessed from either the handset or the base unit.

Using the handset

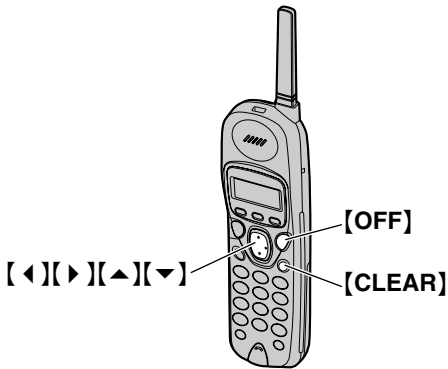

1 Press [**LEFT**] or [**RIGHT**].

```
Directory list
▼▲
▶=Caller's list
```

2 Press [**UP**] or [**DOWN**] until the desired entry is displayed.

Example:

```
Helen
1234567890
```

3 Press [**CLEAR**].

```
Clear?
◀=No      ▶=Yes
```

- To cancel erasing, press [**LEFT**].

4 Press [**RIGHT**] or [**CLEAR**].

```
Clear
```

- The stored name and number are erased.

5 Press [**OFF**] to exit the program.

Using the base unit

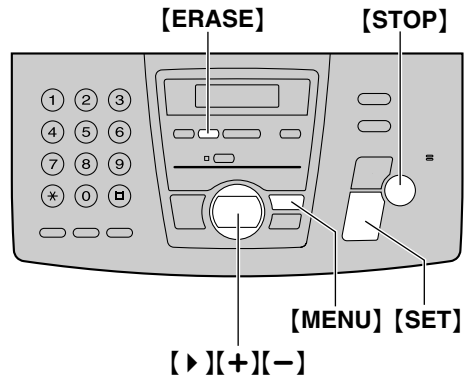

1 Press [**RIGHT**].

- Confirm that there are no documents in the document entrance.

```
DIRECTORY [+ -]
<MAILBOX>
```

2 Press [**PLUS**] or [**MINUS**] until the desired entry is displayed.

Example:

```
PETER
9876543
```



```
PETER
EDIT:PRESS MENU
```

3 Press [**MENU**].

Example:

```
NAME=PETER
EDIT=* DELETE=#
```

4 Press [**PLUS**].

```
DELETE OK?
YES:SET/NO:STOP
```

- To cancel erasing, press [**STOP**].

5 Press [**SET**].

```
DELETED
```

- The stored name and number are erased.

Another method to erase a stored entry

1. Press **[▶]**.
 - Confirm that there are no documents in the document entrance.
2. Press **[+]** or **[-]** until the desired entry is displayed.
3. Press **[ERASE]**.
4. Press **[SET]**.

Making a phone call using the navigator directory

Before using this feature, program the desired names and telephone numbers into the navigator directory (page 41, 42).

Using the handset



- 1 Press **[LEFT]** or **[RIGHT]**.

```
Directory list
▼▲
▶=Caller's list
```

- 2 Press **[UP]** or **[DOWN]** until the desired entry is displayed.

Example: Frank
4567890

- If the desired name has not been stored, press **[OFF]** and dial the number manually.

- 3 Press **[TALK]** or **[SP-PHONE]**.
 - The unit will start dialing automatically.

Using the base unit



- 1 Press **[RIGHT]**.
 - Confirm that there are no documents in the document entrance.

```
DIRECTORY [+ -]
<MAILBOX>
```

- 2 Press **[+]** or **[-]** until the desired entry is displayed.

Example: LISA
2233445



```
LISA
EDIT:PRESS MENU
```

- If the desired name has not been stored, press **[STOP]** and dial the number manually.

- 3 Press **[DIGITAL SP-PHONE]** on the base unit, or lift the handset and press **[TALK]** or **[SP-PHONE]** on the handset.
 - The unit will start dialing automatically.

Navigator Directory

To search for a name by initial

Example: "LISA"

Using the handset

1. Press **[▶]**.
 - Confirm that there are no documents in the document entrance.
2. Press **[▲]** or **[▼]** to enter the directory.
3. Press **[5]** repeatedly until any name with the initial "L" is displayed (see the character table, page 41).
 - To search for symbols (not letters or numbers), press **[*]**.
4. Press **[▲]** until "LISA" is displayed.
 - To stop the search, press **[OFF]**.
 - To make a call, press **[TALK]** or **[SP-PHONE]**.

Using the base unit

1. Press **[▶]**.
 - Confirm that there are no documents in the document entrance.
2. Press **[+]** or **[-]** to enter the directory.
3. Press **[5]** repeatedly until any name with the initial "L" is displayed (see the character table, page 33).
 - To search for symbols (not letters or numbers), press **[*]**.
4. Press **[+]** until "LISA" is displayed.
 - To stop the search, press **[STOP]**.
 - To make a call, press **[DIGITAL SP-PHONE]**.

Caller ID service from your phone company

This unit is compatible with the Caller ID service offered by your local telephone company. To use this feature, you must subscribe to a Caller ID service.

Change the following ring setting to 2 or more rings beforehand.

- TAD ring setting and FAX ring setting (feature #06, page 88)

How Caller ID is displayed

The calling party's name or telephone number will be displayed after the first ring. You then have the option of whether or not to answer the call depending on the caller.

The unit will automatically store the caller information (name, telephone number and the time of the call). You can view the caller information (page 50) and print the Caller ID list (page 111).

Note:

- If the unit is connected to a PBX (Private Branch Exchange) system, you may not receive the caller information. Consult your PBX supplier.
- If the unit cannot receive caller information, the following will be displayed:
 - The caller dialed from an area which does not provide Caller ID service:

Base unit display: OUT OF AREA

Handset display: Out of area

- The caller requested not to send caller information:

Base unit display: PRIVATE CALLER

Handset display: Private caller

- The caller made a long distance call:

Base unit display: LONG DISTANCE

Handset display: Long distance

To confirm caller information using the Caller ID list

The unit will store information for the most recent 30 callers.

- To print manually, see page 111.
- To print automatically after every 30 new calls, activate feature #26 (page 89).

Visual Call Waiting (Call Waiting ID) Service

If you hear a call-waiting tone during a conversation, the display will show the second caller's information.

Press **[CALL WAIT]** to answer the second call.

- The first call is put on hold and you can answer the second call.
- To return to the first caller, press **[CALL WAIT]** again.

Note:

- The second caller's information will not be displayed when:
 - the answering system is recording an incoming message,
 - an extension telephone on the same line is in use, or
 - you are sending or receiving a fax document.
- Please contact your telephone company for details and availability of this service in your area.

Using the base unit

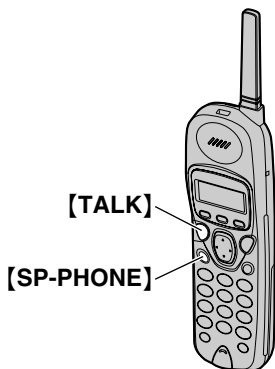
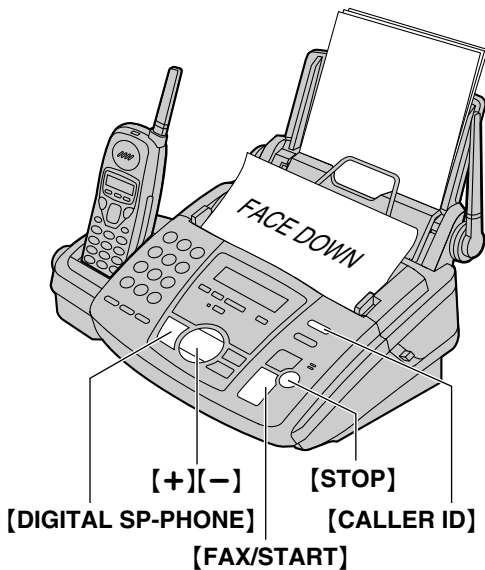

1 Press **[CALLER ID]**.

Example:

2 NEW CALLS PRESS NAVI. [+ -]

2 Press **[+]** to search from the most recent caller information.
Press **[-]** to search from the oldest caller information.

3 Press **[DIGITAL SP-PHONE]**, or lift the handset and press **[TALK]** or **[SP-PHONE]** to call back the displayed party.

- The unit will start dialing automatically.
- To send a fax insert the document **FACE DOWN** and press **[FAX/START]**.

To change the display of the caller information

Press **[CALLER ID]** repeatedly after step 2.

Example:

SAM LEE 11:20AM Jul 20 ✓



1345678901 11:20AM Jul 20 ✓

- Check mark (✓) on the display means the call has already been viewed or answered.

Display while viewing

When the unit could not receive a name:

NO NAME RCVD

When no calls have been received:

NO CALLER DATA

To edit the telephone number for calling back

Press **[*]** repeatedly after step 2. Each time you press **[*]**, the telephone number will be changed as follows:

- 1 - Area code - Local telephone number ("1" added)
2. Local telephone number (area code omitted)
3. Area code - Local telephone number
4. 1 - Local telephone number ("1" added and area code omitted)

To stop viewing

Press **[STOP]** after step 2.

Erasing caller information

You can erase all or specific caller information. Once erased, it cannot be accessed from either the handset or the base unit.

Erasing all caller information using the handset

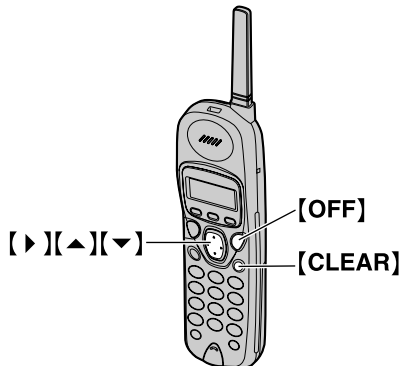

- 1 Lift the handset and press [▲] or [▼].

Example:

```
0 new call
▼▲ ▶=Directory
```

- 2 Press [CLEAR].

```
▶Exit
▶All clear
▼▲ ▶=Yes
```

- 3 Press [▲] or [▼] repeatedly until the arrow points to "All clear".

```
Exit
▶All clear
▼▲ ▶=Yes
```

- To cancel erasing, press [OFF].

- 4 Press [▶] or [CLEAR].

```
All clear
```

Erasing specific caller information using the handset

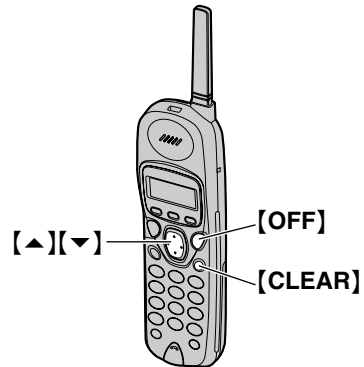

- 1 Lift the handset and press [▲] or [▼].

Example:

```
2 new calls
▼▲ ▶=Directory
```

- 2 Press [▲] or [▼] repeatedly until the desired entry is displayed.

Example:

```
CINDY TURNER
1-234-456-7890
11:20A JAN12
```

- 3 Press [CLEAR].

```
Clear
```

Example:

```
↓
KEVIN PARKER
333-4444
11:50A JAN12
```

- To erase other entries, repeat steps 2 and 3.

- 4 Press [OFF] to exit the program.

Erasing all caller information using the base unit

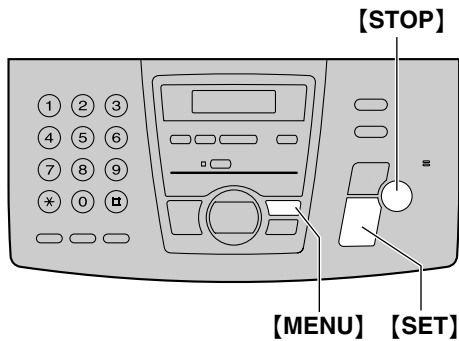

- 1 Press **[MENU]** repeatedly until the following is displayed.

CALLER SET UP
PRESS SET

- 2 Press **[SET]**.

CALL LIST ERASE
PRESS SET

- 3 Press **[SET]**.

ALL ERASE OK?
YES:SET/NO:STOP

- To cancel erasing, press **[STOP]**, then **[MENU]**.

- 4 Press **[SET]**.

ERASE COMPLETED

- 5 Press **[STOP]** to exit the program.

Erasing specific caller information using the base unit

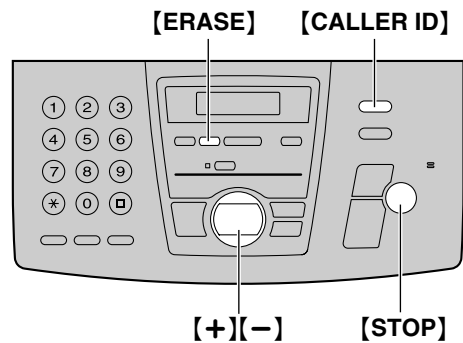

- 1 Press **[CALLER ID]**.

Example: 2 NEW CALLS
PRESS NAVI. [+ -]

- 2 Press **[+]** or **[-]** until the desired entry is displayed.

Example: SAM LEE
12:10AM Jul 20

- 3 Press **[ERASE]**.

DELETED

- To erase other entries, repeat steps 2 to 3.

- 4 Press **[STOP]** to exit the program.

Storing caller information

Important:

- This feature is not available in the following cases.
 - The telephone number includes data other than numbers (i.e. ✕ or †).
 - The caller information does not include a telephone number.

Into the handset

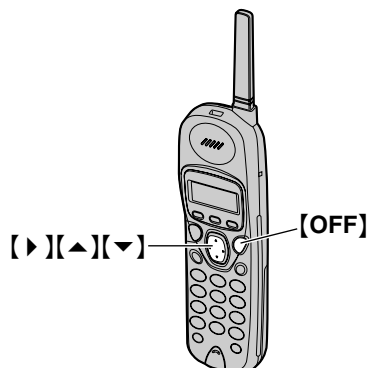

Make sure the handset is idle.

- 1 Lift the handset and press [▲] or [▼].

Example:

3 new calls
▼▲ ▶=Directory

- 2 Press [▲] or [▼] until the desired entry is displayed.

Example:

CINDY TURNER
1-234-456-7890
11:20A JAN12

- 3 Press [▶].

▶Edit
Save directory
▼▲ ▶=Yes

- 4 Press [▲] or [▼] repeatedly until the arrow points to "Save directory".

Edit
▶Save directory
▼▲ ▶=Yes

- 5 Press [▶].

Example:

CINDY TURNER
12344567890

- 6 Press [OFF] to exit the program.

Into the base unit

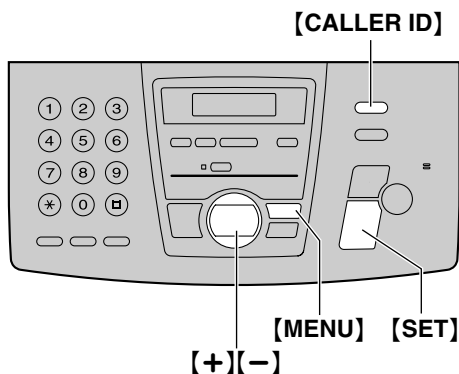

- 1 Press [CALLER ID].

Example:

2 NEW CALLS
PRESS NAVI. [+ -]

- 2 Press [+] or [-] until the desired entry is displayed.

Example:

SAM LEE
11:50AM Apr 14

- 3 Press [MENU].

Example:

NAME=SAM LEE
STORE:PRESS SET

- 4 Press [SET].

Example:

NO.=134567

- 5 Press [SET].

REGISTERED

Note:

- You can confirm the stored entries in the telephone number list (page 111).
- The unit can only store a name of up to 10 characters long.
- To edit a name and number, see page 41.

Sending a fax manually

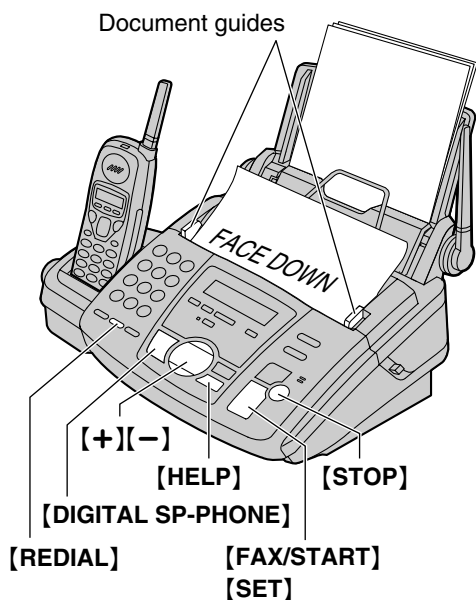

1 Adjust the width of the document guides to the size of the document.

2 Insert the document (up to 10 pages) FACE DOWN until a single beep is heard and the unit grasps the document.

STANDARD
PRESS NAVI. [+ -]

3 If necessary, press **[+]** or **[-]** repeatedly to select the desired resolution.

4 Press **[DIGITAL SP-PHONE]**.

TEL=
PRESS NAVI. [▶]

5 Dial the fax number.

Example: TEL=5678901

6 Start sending.

When a fax tone is heard:

Press **[FAX/START]**.

When the other party answers your call:

Ask them to press their start button. When the fax tone is heard, press **[FAX/START]**.

CONNECTING.....
STANDARD [±]

To select the resolution

Select the desired resolution according to the type of document.

- “**STANDARD**”: For printed or typewritten originals with normal-sized characters.
- “**FINE**”: For originals with small printing.
- “**SUPER FINE**”: For originals with very small printing. This setting only works with other compatible fax machines.
- “**PHOTO**”: For originals containing photographs, shaded drawings, etc.
- Using the “**FINE**”, “**SUPER FINE**” or “**PHOTO**” setting will increase transmission time.
- If the resolution setting is changed during feeding, it will be effective from the next sheet.

To redial the last number

Press **[REDIAL]**.

- If the line is busy, the unit will automatically redial the number up to 2 times.
- During redial, the following will be displayed.

WAITING REDIAL

- To cancel redialing, press **[STOP]**.

Sending Faxes

To send more than 10 pages at a time

Insert the first 10 pages of the document. Add the other pages (up to 10 at a time) before the last page feeds into the unit.

Convenient way to send a fax

You can dial the fax number first before inserting the document. This is convenient if the other party's number is indicated on the document.

1. Enter the fax number.
2. Insert the document.
3. Press **[FAX/START]**.

Sending from memory (Quick scan feature)

You can scan the document into memory before sending. To use this feature, activate feature #34 (page 89).

1. Insert the document.
2. Enter the fax number.
3. Press **[FAX/START]**.
 - The document will be fed into the unit and scanned into memory. The unit will then transmit the data. If the document exceeds the memory capacity, sending will be canceled and this feature will be turned off automatically. Transmit the entire document manually.
 - This feature cannot be used if **[DIGITAL SP-PHONE]**, **[TALK]** or **[SP-PHONE]** is pressed.

To stop transmission

Press **[STOP]**.

Sending a fax with the voice guide

You can send documents by following the voice guide.

1. Press **[HELP]** 2 times.
2. Press **[SET]**.
3. Follow steps 1 to 6 (page 55).
 - After transmission, the voice guide will turn off automatically.

Sending report for confirmation

This report will provide you with a printed record of transmission results. To use this feature, activate feature #04 (page 88). For the communication message in the result column, see page 93.

Journal report

The unit stores the 30 most recent fax communication results. To print manually, see page 111. To print automatically after every 30 new fax communications, activate feature #22 (page 89). For the communication message in the result column, see page 93.

Documents you can send

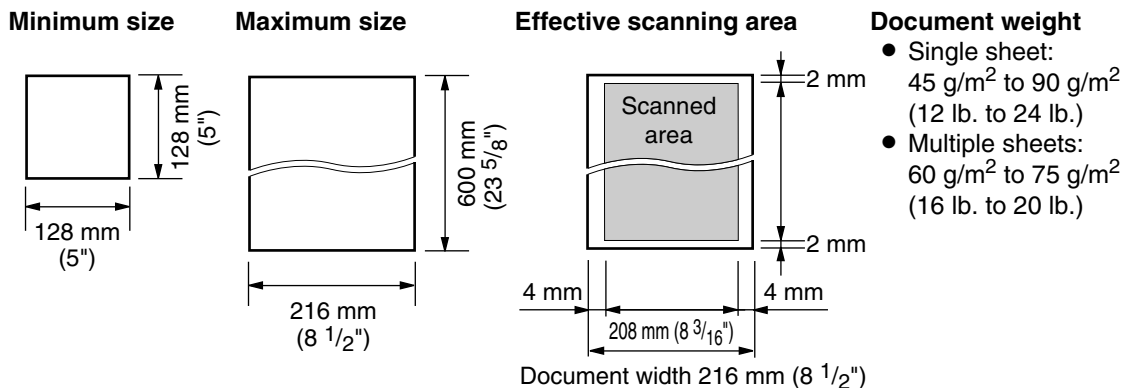

Note:

- Remove clips, staples or other similar fasteners.
- Do not send the following types of documents: (Use copies for fax transmission.)
 - Chemically treated paper such as carbon or carbonless duplicating paper
 - Electrostatically charged paper
 - Badly curled, creased or torn paper
 - Paper with a coated surface
 - Paper with a faint image
 - Paper with printing on the opposite side that can be seen through the other side (i.e. newspaper)
- Check that ink, paste or correction fluid has dried completely.
- To transmit the document with a width of less than standard letter size (216 mm), we recommend using a copy machine to copy the original document onto letter-sized paper, then transmitting the copied document.

Sending Faxes

Sending a fax using the navigator directory

Before using this feature, program the desired names and telephone numbers into the navigator directory (page 41).

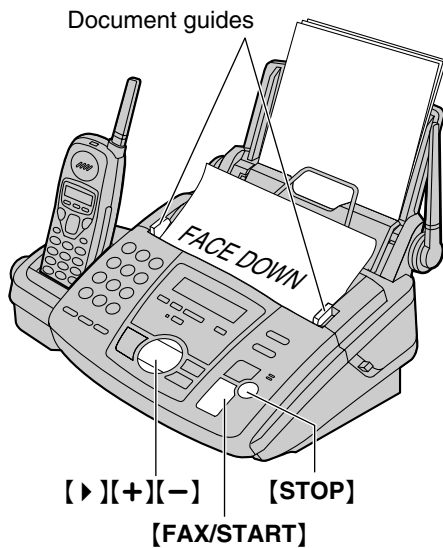

Fax auto redial

If the line is busy or if there is no answer, the unit will automatically redial the number up to 2 times.

- This feature is also available for delayed transmission (feature #25, page 89).
- During redial, the following will be displayed.

WAITING REDIAL

- To cancel redialing, press **[STOP]**.

If your unit does not send a fax

- Confirm the stored telephone number on the display and check that the number dialed is answered by the other party's machine.
- The connecting tone will be heard during dialing to tell you the status of the other party's machine (feature #76, page 92).

1 Adjust the width of the document guides to the size of the document.

2 Insert the document (up to 10 pages) FACE DOWN until a single beep is heard and the unit grasps the document.

STANDARD
PRESS NAVI. [+ -]

3 If necessary, press **[+]** or **[-]** repeatedly to select the desired resolution (page 55).

4 Press **[▶]**.

DIRECTORY [+ -]
<MAILBOX>▶

5 Press **[+]** or **[-]** to display the desired entry and press **[FAX/START]**.

- If the desired name has not been stored in the navigator directory, press **[STOP]** and dial the number manually.

Broadcast transmission

This feature is useful for sending the same document to more than one party (up to 20 entries). First program the entries, then see page 61 for transmission.

Programming entries into the broadcast memory

Note:

- If you program the wrong entry, press **[STOP]** after step 4 to erase the entry.
- Confirm the stored entries by printing a broadcast programming list (page 111).

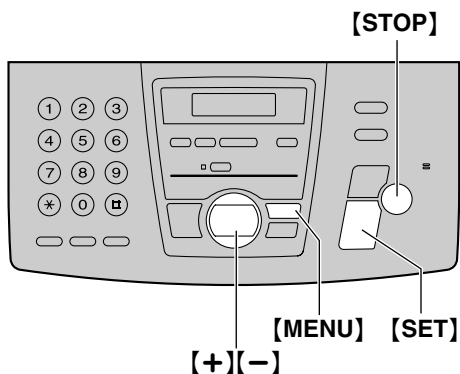

- 1** Press **[MENU]** repeatedly until the following is displayed.

```
DIRECTORY SET
NAVI. =* BROAD=#
```

- 2** Press **[#]**.

```
DIR= [00]
NAVI. [+ -] & SET
```

- The number in brackets indicates the number of registered entries.

- 3** Press **[+]** or **[-]** until the desired entry is displayed.

Example:

```
MIKE
1-987-654-3210
```

- 4** Press **[SET]**.

Example:

```
DIR=MIKE [01]
STORE:PRESS SET
```

- To program other entries, repeat steps 3 and 4 (up to 20 entries).

- 5** Press **[SET]** to exit the program.

```
REGISTERED
```

Sending Faxes

Adding a new entry into the broadcast memory

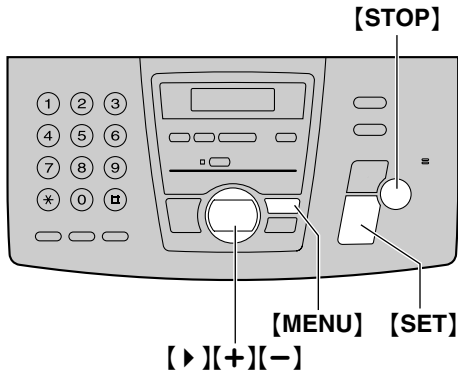

- 1 Press **[▶]**.
 - Confirm that there are no documents in the document entrance.

DIRECTORY [+ -]
<MAILBOX>

- 2 Press **[-]** or **[+]** until the following is displayed.

<BROADCAST>
EDIT:PRESS MENU

- 3 Press **[MENU]**.

BROADCAST
ADD=* DELETE=#

- 4 Press **[*]**.

- 5 Press **[+]** or **[-]** until the desired entry you want to add is displayed.

Example: MARY
15843724123

- 6 Press **[SET]**.

REGISTERED

Example: NIKKI
13852179365

- To add other entries, repeat steps 5 and 6 (up to 20 entries).

- 7 Press **[STOP]** to exit the program.

Erasing a stored entry in the broadcast memory

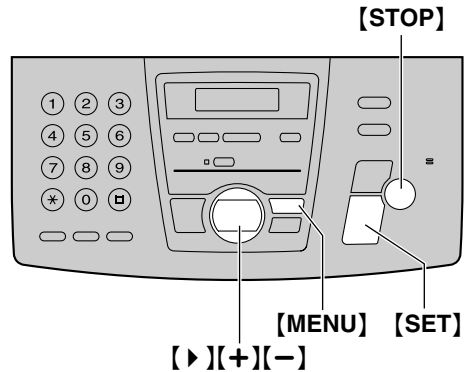

- 1 Press **[▶]**.
 - Confirm that there are no documents in the document entrance.

DIRECTORY [+ -]
<MAILBOX>

- 2 Press **[-]** or **[+]** until the following is displayed.

<BROADCAST>
EDIT:PRESS MENU

- 3 Press **[MENU]**.

BROADCAST
ADD=* DELETE=#

- 4 Press **[#]**.

- 5 Press **[+]** or **[-]** until the desired entry you want to erase is displayed.

Example: DICK
13281432968

- To cancel erasing, press **[STOP]**.

- 6 Press **[SET]**.

DELETE OK?
YES:SET/NO:STOP

- 7 Press **[SET]**.

DELETED

Example: BOB
0123456

- To erase other entries, repeat steps 5 to 7.

- 8 Press **[STOP]** to exit the program.

Sending the same document to pre-programmed parties

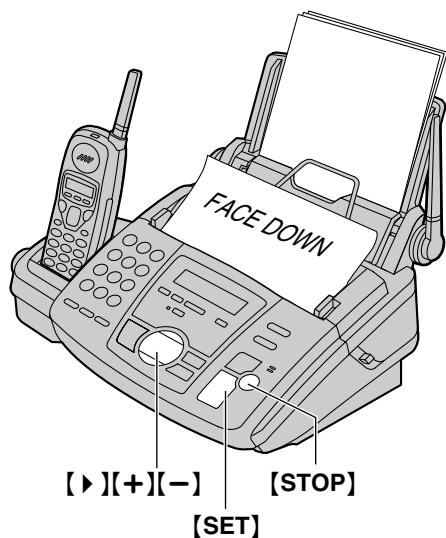

- 1 Insert the document **FACE DOWN**.
 - If necessary, press **[+]** or **[-]** repeatedly to select the desired resolution (page 55).
- 2 Press **[▶]**.

DIRECTORY [+ -]
<MAILBOX>▶
- 3 Press **[-]** or **[+]** until the following is displayed.

<BROADCAST>
SEND:PRESS SET
- 4 Press **[SET]**.
 - The document will be fed into the unit and scanned into memory. The unit will then transmit the data to each entry, calling each number sequentially.
 - After transmission, the stored document will be erased automatically, and the unit will automatically print a broadcast sending report.

Note:

- If you select "FINE", "SUPER FINE" or "PHOTO" resolution, the number of pages that the unit can transmit will decrease.
- If the document exceeds the memory capacity, sending will be canceled.
- If one of the entries is busy or does not answer, it will be skipped. All skipped entries will be redialed up to 2 times after all of the other entries have been called.

To send the same document to more than one party only once

You can also select the parties for each transmission.

1. Insert the document.
2. Press **[▶]**.
3. Press **[-]** or **[+]** until the following is displayed.

<ONE TIME BROAD>
PRESS SET

4. Press **[SET]** to start programming the entries you want to transmit to.

DIR= [00]
NAVI.[+ -] & SET

5. Press **[+]** or **[-]** until the desired entry you want to transmit to is displayed.

Example:

BILL
6543210

6. Press **[SET]**.

Example:

DIR=BILL [01]
SEND:PRESS SET

- To program other entries, repeat steps 5 and 6 (up to 20 entries).

7. Press **[SET]** to start transmission to the programmed entries.

To cancel the broadcast setting

1. Press **[STOP]** while the unit displays the following.

BROADCASTING

- The display will show the following.

SEND CANCELED?
YES:SET/NO:STOP

2. Press **[SET]**.

Receiving Faxes

Receiving a fax manually

Activating TEL mode

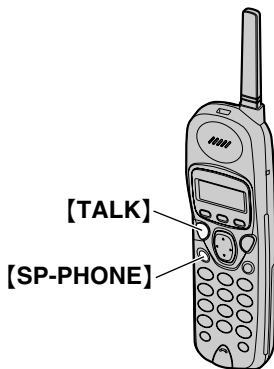
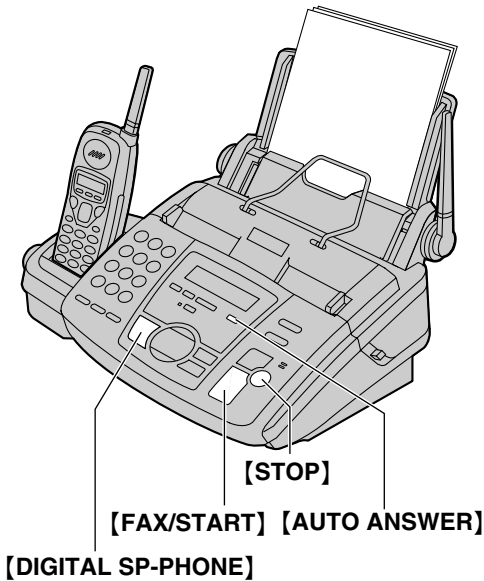

Set the fax machine to TEL mode by pressing **[AUTO ANSWER]** until the following is displayed.

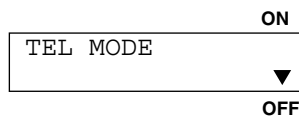

How to receive calls using the base unit

- 1 When the fax machine rings, press **[DIGITAL SP-PHONE]** or lift the handset and press **[TALK]** or **[SP-PHONE]** to answer the call.
- 2 When document reception is required, a fax calling tone (slow beep) is heard, or no sound is heard, press **[FAX/START]**.

CONNECTING.....

- The unit will start fax reception.

How to receive calls using the handset

- 1 When the fax machine rings, lift the handset and press **[TALK]** or **[SP-PHONE]**.
- 2 When document reception is required, a fax calling tone (slow beep) is heard, or no sound is heard, press **[*][#][9]** (pre-selected fax activation code) **firmly**.
 - A single beep will be heard.
 - The unit will start fax reception.

Note:

- To receive fax documents using the handset, you must set the remote fax activation to on (feature #41, page 90) beforehand.
- You can change the fax activation code in feature #41 (page 90).
- If you do not answer the call within 10 rings, the unit will temporarily activate the answering device. The greeting message will then be played and the other party can then send a fax.

To stop receiving

Press **[STOP]**.

Extension telephone

If you use the fax machine with an extension telephone, you can receive fax documents using the extension telephone. You do not have to press **[FAX/START]** on the fax machine.

Important:

- **Use a touch tone telephone as the extension telephone and enter the fax activation code firmly.**
1. When the extension telephone rings, lift the handset of the extension telephone.
 2. When document reception is required, a fax calling tone (slow beep) is heard, or no sound is heard, press **[*][#][9]** (pre-selected fax activation code) **firmly**.
 3. Replace the handset.
 - The fax machine will start reception.

Note:

- To receive fax documents using the extension telephone, you must set the remote fax activation to on (feature #41, page 90) beforehand.
- You can change the fax activation code in feature #41 (page 90).

Receiving Faxes

Receiving a fax automatically

Activating FAX ONLY mode

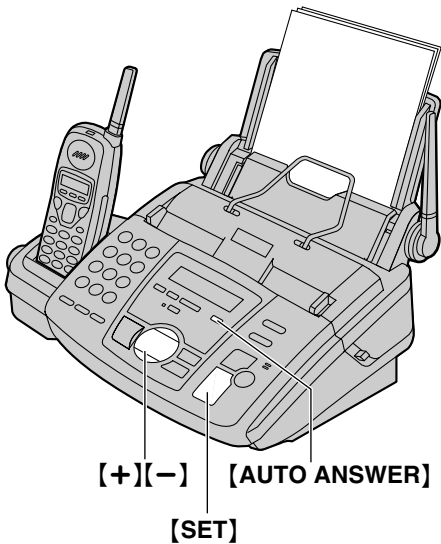

- 1 Set feature #77 to “FAX ONLY” (page 92).
- 2 Press **[AUTO ANSWER]** until the following is displayed.

	ON
FAX ONLY MODE ▲	
3 RINGS	
	OFF

- The display will show the number of rings before the unit answers a call in FAX ONLY mode.

- 3 Press **[+]** or **[-]** to change the ring setting to 2 and press **[SET]**.

How to receive calls

When receiving calls, the unit will automatically answer all calls and only receive fax documents.

Activating TAD/FAX mode

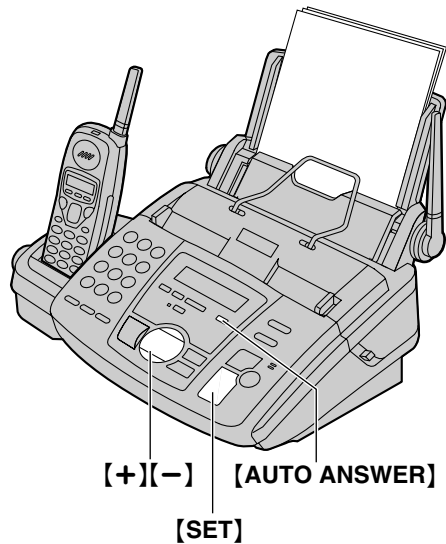

- 1 Set feature #77 to “TAD/FAX” (page 92).
- 2 Press **[AUTO ANSWER]** until the following is displayed.

	ON
TAD/FAX MODE ▲	
2 RINGS	
	OFF

- The unit will play the pre-recorded greeting message.
- The display will show the number of rings before the unit answers a call in TAD/FAX mode.
- If you wish to change the ring setting, press **[+]** or **[-]** until the desired setting is displayed, and press **[SET]**.
- You can adjust the speaker volume after changing the ring setting. Press **[+]** or **[-]** while listening to the greeting message.
- The remaining time for recording incoming messages will be displayed.

Example:

TIME = 10m13s

Note:

- The incoming message recording time can be changed (feature #10, page 88).
- When the remaining time is low, erase unnecessary messages (page 75).
- While an incoming call is being recorded, you can monitor it through the speaker. If this feature is not required, set feature #67 to off (page 91).

How to receive calls

When receiving calls, the unit works as a fax and/or answering device.

- If the call is a phone call, the answering machine will record a voice message automatically.
- If a fax calling tone is detected, the fax machine will receive a fax automatically.

Ring setting in TAD/FAX mode

You can choose from 1, 2, 3, 4, "TOLL SAVER" and "RINGER OFF". This setting can be changed by feature #06, page 88.

- **"TOLL SAVER"**: When you call the unit from a remote location, the number of rings will tell you if there are any new voice messages. If the unit answers on the 2nd ring, there is at least one new recorded message. If the unit answers on the 4th ring, there are no new recorded messages. To save the toll charges for the call, hang up immediately when you hear the 3rd ring. The 3rd ring indicates that there are no new recorded messages.
- **"RINGER OFF"**: The unit will answer without ringing.
 - If you subscribe to a Caller ID service, set to 2 or more rings.

Distinctive Ring

Using two or more phone numbers in a single telephone line

The Distinctive Ring service is a service offered by your local telephone company. This service provides several telephone numbers for a single telephone line, and the ring pattern differs according to which telephone number the call was addressed to. Originally, this service was designed for the purpose of allowing different ring patterns to distinguish which number the call was addressed to.

This unit distinguishes the different ring patterns. If the ring pattern is one which is assigned for a fax, the fax machine will automatically start fax reception. This service is convenient if you wish to have a different number for fax in a single telephone line.

To use this service, you must subscribe to the Distinctive Ring service offered by your local telephone company.

Activating the Distinctive Ring feature

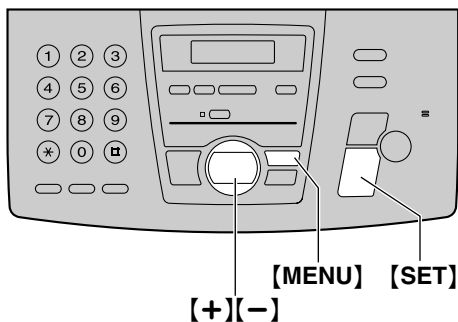

How to receive calls

If the incoming call is for the fax number, the fax machine will ring with the assigned ring pattern and automatically start fax reception.

If the incoming call is for the phone number;

- the fax machine will keep on ringing in TEL mode.
- the fax machine will record voice message in TAD/FAX mode.
- fax communication will be attempted in FAX ONLY mode.

1 Press **[MENU]**.

```
SYSTEM SET UP  
PRESS NAVI. [◀ ▶]
```

2 Press **[#]**, then **[3][1]**.

```
DISTINCTIVE RING  
MODE=OFF [±]
```

3 Press **[+]** or **[-]** to select "ON".

```
DISTINCTIVE RING  
MODE=ON [±]
```

4 Press **[SET]**.

5 Press **[MENU]**.





If you use three or more phone numbers

You may wish to use three or more phone numbers for a single telephone line to distinguish which number the call was addressed to. A different ring pattern must be assigned for each number.

Example: Using three phone numbers

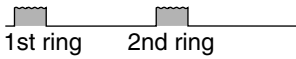
Telephone number	Ring pattern	Use
012 1234	Standard ring	Personal
012 5678	Double ring	Business
012 9876	Triple ring	Fax

To use one phone number for the fax, program the ring pattern assigned for the fax in feature #32. In the example, the ring pattern assigned for fax is triple ring, so you should program "C" (triple ring).

Ring pattern	Settings in feature #32
Standard ring (one long ring)  1st ring 2nd ring	A
Double ring (two short rings)  1st ring 2nd ring	B
Triple ring (short-long-short rings)  1st ring 2nd ring	C
Other triple ring (short-short-long rings)  1st ring 2nd ring	D

Programming the ring pattern assigned for fax

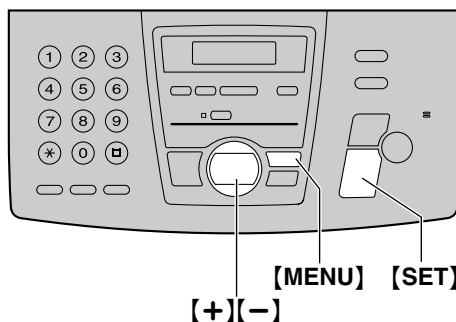

1 Press **[MENU]**.

```
SYSTEM SET UP
PRESS NAVI. [◀ ▶]
```

2 Press **[#]**, then **[3][2]**.

```
FAX RING PATTERN
RING=B-D [±]
```

3 Press **[+]** or **[-]** to select the ring pattern assigned for fax.

A: Standard ring (one long ring)

B: Double ring (two short rings)

C: Triple ring (short-long-short-rings)

D: Other triple ring (short-short-long rings)

B-D (default setting): For the ring pattern of B, C and D

4 Press **[SET]**.

5 Press **[MENU]**.

Copying

Making a copy

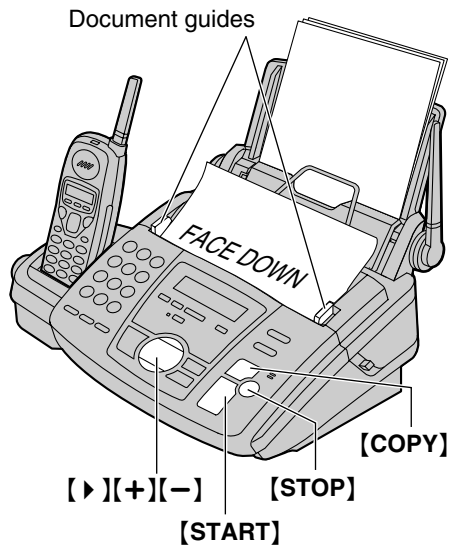

- 1 Adjust the width of the document guides to the size of the document.
 - Confirm that there is enough recording paper in the recording paper entrance.

- 2 Insert the document (up to 10 pages) FACE DOWN until a single beep is heard and the unit grasps the document.

```
STANDARD  
PRESS NAVI . [+ -]
```

- 3 If necessary, press **[+]** or **[-]** repeatedly to select the desired resolution.

- 4 Press **[COPY]**.

```
NUMBER=1  
COPY:PRESS START
```



```
NUMBER=1  
OR PRESS NAVI . ▶
```

- If necessary, enter the number of copies (up to 50).

- 5 Press **[START]**.
 - The unit will start copying.
 - If you do not press **[START]** for 15 seconds, the unit will start copying automatically.

Note:

- Any transmittable document can be copied (page 57).

To select the resolution

Select the desired resolution according to the type of document.

- **“FINE”**: For printed or typewritten originals with small printing.
- **“SUPER FINE”**: For originals with very small printing.
- **“PHOTO”**: For originals containing photographs, shaded drawings, etc.
 - If you select “STANDARD”, copying will be done using “FINE” mode.

Quick scan feature

This feature is helpful when you want to copy the document, then remove it for other uses. To use this feature, activate feature #34 (page 89).

- The document will be fed into the unit and scanned into memory. The unit will then print the data.

If the document exceeds the memory capacity, copying of the exceeded document will be canceled and this feature will be turned off automatically.

To stop copying

Press **[STOP]**.

Convenient way of copying

To enlarge a document

1. Press **[▶]** after step 4 on page 68.

```
ZOOM 100% [+ -]
<COLLATE>▶
```

2. Press **[+]** to select "150%" or "200%", then press **[START]**.

- The unit will only enlarge the centermost part of the document, printing it on two pages.

Example: 150% enlarged copy

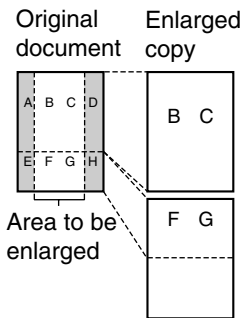

Example: 200% enlarged copy

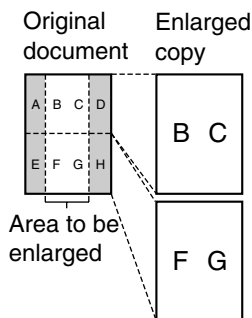

To reduce a document

1. Press **[▶]** after step 4 on page 68.

```
ZOOM 100% [+ -]
<COLLATE>▶
```

2. Press **[−]** to select "92%", "86%" or "72%", then press **[START]**.

- See the following table for the recommended reduction rates.

Setting	Recording paper size	Original document size
100% (default)	Letter	Letter
	Legal	Letter, A4, Legal
	A4	A4, Letter
92%	Letter	A4
86%	Letter	A4
72%	Letter	Legal
	A4	Legal

Letter = 216 mm × 279 mm (8¹/₂" × 11")

Legal = 216 mm × 356 mm (8¹/₂" × 14")

A4 = 210 mm × 297 mm (8¹/₄" × 11¹¹/₁₆")

Note:

- If the appropriate reduction rate is not selected, the document may be divided and the top of the second sheet will be deleted.
- If the image at the bottom of the document is not copied when you copy a document that is the same length as the recording paper, try 92% or 86%.

Copying

To collate multiple copies

The unit can collate multiple copies in the same order as the original document pages.

1. After step 4 on page 68, press **[▶]** 2 times.

```
COLLATE OFF [+ -]  
<RESOLUTION>▶
```

2. Press **[+]** or **[-]** repeatedly until the following is displayed.

```
COLLATE ON [+ -]  
<RESOLUTION>▶
```

3. Press **[START]**.

Example: Making 2 copies of a 4-page original document

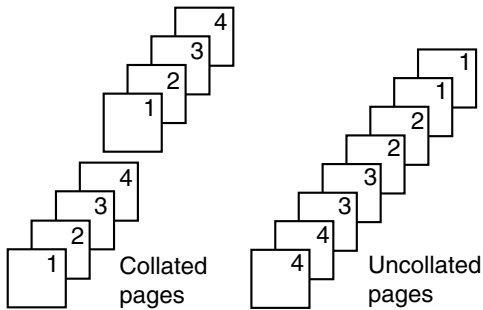

Note:

- The unit will store the documents into memory while collating the copies. If memory becomes full while storing, the unit will only print out the stored pages.
- After copying, the collating feature will turn off automatically.

Recording your own greeting message

You can record your own greeting message for TAD/FAX mode. The recording time will be limited to 16 seconds. We recommend you record a message less than 12 seconds in length to make it easier to receive faxes.

Suggested message for TAD/FAX greeting: "This is (your name, business and/or telephone number). We are unable to answer right now. To send a fax, start transmission. To leave a message, speak after the beep. Thank you."

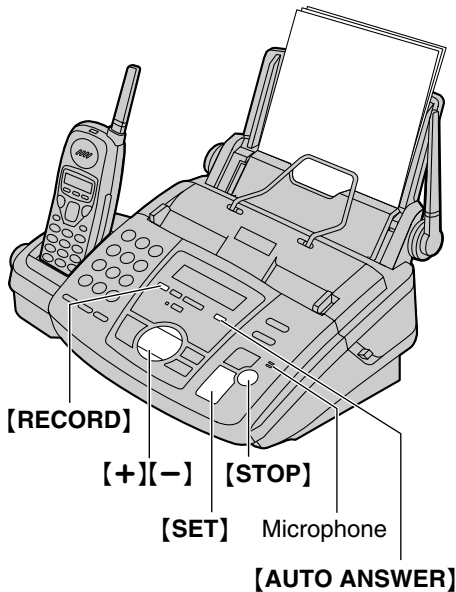

Note:

- You can choose 60 seconds for your own TAD/FAX greeting message (feature #54, page 91).
 - If you change to 60 seconds, we recommend that you tell the caller in your own TAD/FAX greeting message to press *9 before starting fax transmission.
 - If you change to 16 seconds from 60 seconds, your own TAD/FAX greeting message will be deleted. When receiving a call, the pre-recorded greeting message will be played.

Checking the greeting message

1. Set feature #77 to "TAD/FAX" (page 92) beforehand.
2. Press **[AUTO ANSWER]** until the following is displayed.

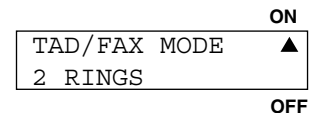

- The unit will play the greeting message.

1 Set feature #77 to "TAD/FAX" (page 92) beforehand.

2 Press **[RECORD]** until the following is displayed.

TAD GREETING PRESS SET

3 Press **[SET]**.

- A long beep will sound.

4 Speak clearly about 20 cm (8 inches) away from the microphone.

- The display will show the remaining recording time.

TAD REC. 16s

5 When finished recording, press **[STOP]**.

- The unit will repeat your message.
- Adjust the volume using **[+]** or **[-]**.

Greeting

Erasing your own recorded greeting message

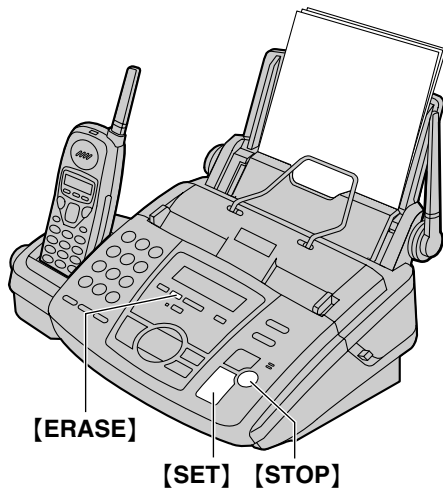

1 Set feature #77 to “TAD/FAX” (page 92) beforehand.

2 Press **[ERASE]** until the following is displayed.

```
TAD GREETING
PRESS SET
```

3 Press **[SET]**.

```
ERASE GREETING?
YES : SET / NO : STOP
```

- To cancel erasing, press **[STOP]**.

4 Press **[SET]**.

```
GREETING ERASED
```

Note:

- If you erase your own TAD/FAX greeting message, the pre-recorded greeting message will be played when receiving a call.

Leaving a message for others or yourself

To leave a private message for yourself or someone else, you can record a voice memo. This memo can be played back later, either directly or remotely.

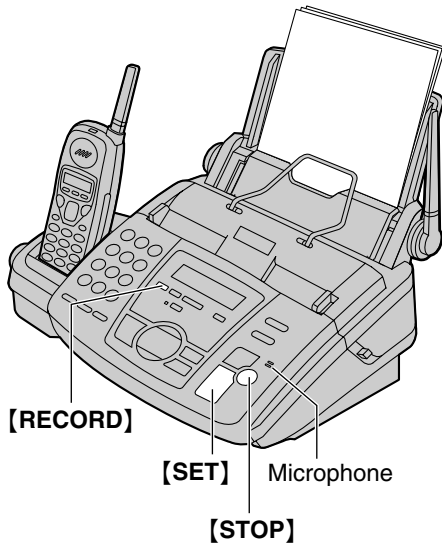

- 1** Press **[RECORD]**.

MEMO MESSAGE
PRESS SET

- 2** Press **[SET]**.
 - A long beep will sound.

MEMO RECORDING

- 3** Speak clearly about 20 cm (8 inches) away from the microphone.
- 4** When finished recording, press **[STOP]**.

Incoming Messages

Listening to recorded messages using the base unit

When the unit has recorded new voice messages:

- The PLAY MESSAGES indicator will flash.
- The display will show the total number of recorded messages.

Example:

02

- Slow beeps will sound if the message alert feature is activated (feature #42, page 90).

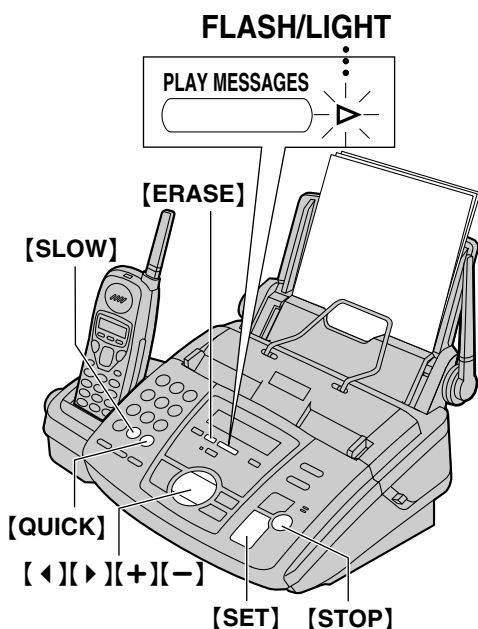

Press **[PLAY MESSAGES]**.

- Only the new recorded messages will be played.
- Adjust the speaker volume using **[+]** or **[-]**.
- After playing back all of the new messages, the PLAY MESSAGES indicator will stop flashing but will remain lit up. If you press **[PLAY MESSAGES]** at this time, all the recorded messages will be played.

To repeat a message

Press **[LEFT]** while listening to the message.

- If you press **[LEFT]** within 5 seconds of the beginning of the message, the previous message will be played.
- To play back a specific message, press **[LEFT]** or **[RIGHT]** and search for the message you want to listen to.

To skip a message

Press **[RIGHT]** to play the next message.

To stop playback

Press **[STOP]**.

- If you press **[PLAY MESSAGES]** within 1 minute, the unit will resume playing the rest of the messages.

Voice time/day stamp

During playback, a synthesized voice will announce the time and day of the week that each message was recorded.

To change the playback speed

Press **[QUICK]** to play messages at one and a half times the original speed. Press **[SLOW]** to play messages at half the original speed.

- To return to the original speed, press **[QUICK]** or **[SLOW]** again during quick or slow playback.

Erasing recorded messages

To erase a specific message

Press **[ERASE]** while listening to the message you want to erase.

To erase all the messages

Check that you have listened to all of the recorded messages.

1. Press **[ERASE]**.

ALL MESSAGES PRESS SET

2. Press **[SET]**.

ERASE MESSAGES? YES : SET / NO : STOP
--

3. Press **[SET]**.

- Messages recorded in voice mailbox will not be erased.

Incoming Messages

Listening to recorded messages using the handset

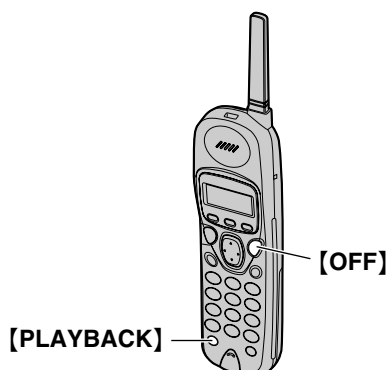

1 Press **[PLAYBACK]**.

Remote
operation
[||||]

The voice guide will tell you the number of new messages and they will be played automatically.

Voice guide example:
"3 new messages."

To repeat only the new messages:

Press **[4]**.

To listen to all the messages:

Press **[5]**.

2 Press **[OFF]** to end the operation.

When there are no new messages

Voice guide:

"No new messages."

Wait for 4 seconds or press **[5]** to listen to all the messages.

When voice memory is full

Voice guide:

"Sorry, no more memory. Please erase unnecessary messages."

The voice guide will be heard after playing back the messages.

Erase unnecessary messages.

To repeat a message

Press **[1]** while listening to the message.

- If you press this key within 5 seconds of the beginning of a message, the previous message will be played.

To skip a message

Press **[2]** to play the next message.

To erase a specific message

Press **[*][4]** while listening to the message you want to erase.

Voice guide:

"The message has been erased."

- A long beep will sound. The unit will then play back the next message.

To erase all the messages

Press **[*][5]** to erase all the messages.

Voice guide:

"All messages have been erased."

- A long beep will sound.

To turn AUTO ANSWER on or off

To turn AUTO ANSWER on (TAD/FAX mode), press **[7]**.

To turn AUTO ANSWER off (TEL mode), press **[9]**.

Operating from a remote location

You can call your unit from a remote location and access the answering device.

Important:

- Program the remote operation ID beforehand (feature #11, page 88).
- Set the unit to TAD/FAX mode before going out (page 64).
- Use a touch tone telephone for remote operations.

Helpful hint:

- Please cut off or make a copy of the card (page 129), and carry the card when you go out.
- When you press a key, press firmly.
- Press the remote command key within 10 seconds.

Listening to recorded messages

- 1** Call your unit.
- 2** Press the remote operation ID during the TAD/FAX greeting message.
- 3** Start remote operations.

When there are new recorded messages

The voice guide will tell you the number of new messages and they will be played automatically.

Voice guide example:
"3 new messages."

When there are no new messages

Voice guide:
"No new messages."

Wait for 4 seconds or press **[5]** to listen to all the messages.

When voice memory is full

Voice guide:
"Sorry, no more memory. Please erase unnecessary messages."

The voice guide will be heard after playing back the messages.

Erase unnecessary messages.

Remote operations using the remote command key

[1]: repeats a message. If you press this key within 5 seconds of the beginning of a message, the previous message will be played.

[2]: skips a message.

[4]: repeats only the new messages.

[5]: plays back all the messages.

Remote Operation

Other remote operations

Erasing a specific message

Press **[*][4]** while listening to the message you want to erase.

Voice guide example:

"The message has been erased."

- A long beep will sound. The unit will then play back the next message.

Erasing all the messages

Press **[*][5]** to erase all the messages.

Voice guide example:

"All messages have been erased."

- A long beep will sound.

Monitoring the room

Press **[6]** to monitor the sound for about 30 seconds in the room where the unit is installed.

- After 30 seconds, a beep will sound. To continue monitoring, press **[6]** again within 10 seconds.

Recording a marker message

After playing back the recorded messages, you can leave an additional message.

1. Wait for the voice guide.

Voice guide example:

"All messages have been played."

2. Wait about 10 seconds.

Voice guide example:

"Please leave your name and message after the beep."

3. Leave a message after the beep.

Re-recording a greeting message

You can change the contents of the TAD/FAX greeting message.

1. Press **[7]** to start recording.

- A long beep will sound.

2. Speak clearly up to 16 seconds.

- If you pause for over 2 seconds, 6 beeps will sound and the recording will stop. Repeat from step 1 within 10 seconds.

3. When finished recording, press **[9]**.

- The new greeting message will be played.

Skipping the greeting message

Press **[0]** during the greeting message playback.

- The unit will skip the rest of the greeting message.

Turning the message transfer on or off

You must program a transfer telephone number beforehand (feature #60, page 91).

Press **[8][1]** to turn on the message transfer.

Voice guide example:

"Message transfer is set. Transfer phone number is 123..."

Press **[8][2]** to turn off the message transfer.

Voice guide example:

"Message transfer is off."

- If a transfer telephone number is not programmed, you cannot turn this feature on.

Voice guide example:

"Transfer phone number is not set."

Turning the pager call on or off

You must program a pager number beforehand (feature #70, page 91).

Press **[8][3]** to turn on the pager call.

Voice guide example:

"Pager call is set. Pager number is 098765432."

Press **[8][4]** to turn off the pager call.

Voice guide example:

"Pager call is off."

- If a pager number is not programmed, you cannot turn this feature on.

Voice guide example:

"Pager number is not set."

Changing the receive mode

Press **[8][0]** to change the receive mode from TAD/FAX to TEL.

- You cannot return to TAD/FAX mode in the same call. To return to TAD/FAX mode, see the following.

Setting to TAD/FAX mode from TEL mode

1. Call your unit and wait for 10 rings.

- The answering device will temporarily answer the call.

2. Enter the remote operation ID during the greeting message.

- A long beep will sound, and your unit will switch to TAD/FAX mode.

3. Hang up the handset.

How callers can leave you private messages

This unit has two mailbox memories. Your caller can leave a private message in a specific mailbox. Only the person who knows the password can retrieve a message from a mailbox. This feature is useful when you share this unit with other people.

To use a mailbox

- 1** Record your own TAD/FAX greeting message (page 71).
Suggested message: *"This is (your name). We are unable to answer right now. To send a fax, start transmission. To leave a message, speak after the beep. To leave a private message, press * and the desired mailbox number 1 or 2. Thank you."*
- 2** Record your own mailbox greeting message if necessary (page 80).
Suggested message: *"This is (personal name). Please leave your name and message after the beep."*
- 3** Change the mailbox password if necessary.
 - For mailbox 1 password, see feature #51 (page 91).
 - For mailbox 2 password, see feature #52 (page 91).
- 4** Set the unit to TAD/FAX mode (page 64).

How incoming messages are recorded in a mailbox

- 1** Call your unit from a remote touch tone telephone.
 - The TAD/FAX greeting message will be played.
 - 2** Press [*****] and the desired mailbox number (**[1]** or **[2]**).
 - A mailbox greeting message will be played.
 - 3** After the beep, leave a message.
- Note:**
- If the caller does not enter the mailbox number in step 2, the message will be recorded in the common memory.

Recording your own mailbox greeting messages

The recording time is limited to 16 seconds for each mailbox.

Suggested message: "This is (personal name). Please leave your name and message after the beep."

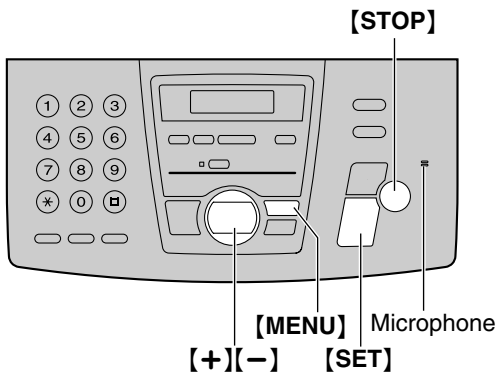

- 1 Press **[MENU]**.

```
SYSTEM SET UP  
PRESS NAVI. [◀ ▶]
```

- 2 Select a mailbox.

For mailbox 1:

Press **[#]**, then **[5][5]**.

```
BOX1 GREETING  
CHECK [±]
```

For mailbox 2:

Press **[#]**, then **[5][6]**.

```
BOX2 GREETING  
CHECK [±]
```

- 3 Press **[+]** or **[-]** to select "RECORD".

Example:

```
BOX1 GREETING  
RECORD [±]
```

- 4 Press **[SET]**.

- 5 Speak clearly about 20 cm (8 inches) away from the microphone.

- The display will show the remaining recording time.

Example:

```
BOX1 REC. 16s
```

- 6 When finished recording, press **[STOP]**.

- The unit will repeat your message.
Adjust the volume using **[+]** or **[-]**.

- 7 Press **[MENU]**.

To check the mailbox greeting message

1. For mailbox 1, press **[MENU]**, **[#][5][5]**.
For mailbox 2, press **[MENU]**, **[#][5][6]**.
2. Press **[+]** or **[-]** to select "CHECK".
3. Press **[SET]**.
 - The unit will play the message.
4. Press **[MENU]**.

To erase your own mailbox greeting message

1. For mailbox 1, press **[MENU]**, **[#][5][5]**.
For mailbox 2, press **[MENU]**, **[#][5][6]**.
2. Press **[+]** or **[-]** to select "ERASE".
3. Press **[SET]**.
 - Your own message will be erased.
4. Press **[MENU]**.

Listening to recorded messages using the base unit

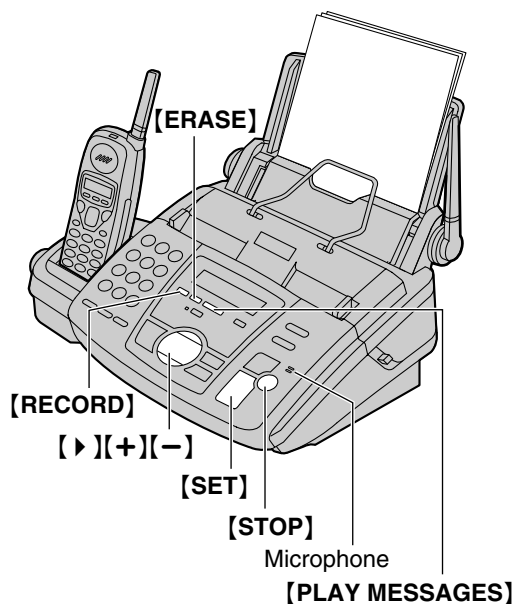

1 Press **[▶]** 2 times.

MAILBOX [+ -]

2 Press **[+]** or **[−]** until the desired mailbox number is displayed.

Example: NEW MESSAGES
MAILBOX2 [±] 02

PRESS
REC/ERASE/PLAY

3 Press **[PLAY MESSAGES]**.

If you have programmed your own mailbox password, enter it.

PASSWORD=

- Only the new recorded messages will be played.
- If there are no new messages, the unit will play back all the recorded messages.

4 Press **[STOP]** to end the operation.

Note:

- The following features can be used during playback. See page 74, 75 for details.
 - To repeat a message
 - To skip a message
 - To stop playback
 - To change the playback speed
 - To erase a specific message

To record a memo message into a mailbox

1. Press **[▶]** 2 times.

MAILBOX [+ -]

2. Press **[+]** or **[−]** until the desired mailbox number is displayed.

Example: MAILBOX1 [±] 00



PRESS
REC/ERASE/PLAY

3. Press **[RECORD]**.

- A long beep will sound.

Example: BOX1 RECORDING

4. Speak clearly about 20 cm (8 inches) away from the microphone.

5. When finished recording, press **[STOP]**.

To erase all the messages in a mailbox

1. Press **[▶]** 2 times.

2. Press **[+]** or **[−]** until the desired mailbox number is displayed.

Example: MAILBOX1 [±] 01



PRESS
REC/ERASE/PLAY

3. Press **[ERASE]**.

BOX1 ERASE OK?
YES:SET/NO:STOP

4. Press **[SET]**.

Listening to recorded messages using the handset

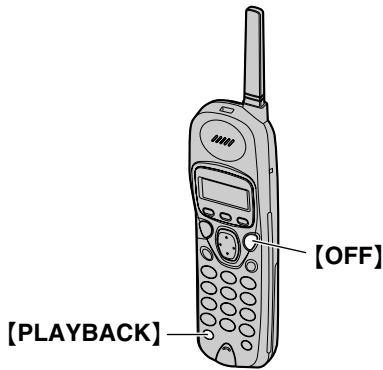

Note:

- The following features can be used during playback. See page 76 for details.
 - To repeat a message
 - To skip a message
 - To erase a specific message
 - To erase all the messages
- For the following, see page 76:
 - When there are no new recorded messages.
 - When voice memory is full.

1 Press **[PLAYBACK]**.

Remote
operation
[■■■■]

2 Select a mailbox.

For mailbox 1:

Press **[*][1]**.

For mailbox 2:

Press **[*][2]**.

3 Enter the mailbox password (default setting "555").

The voice guide will tell you the number of new messages and they will be played automatically.

Voice guide example:
"3 new messages."

To repeat only the new messages:

Press **[4]**.

To listen to all the messages:

Press **[5]**.

4 Press **[OFF]** to end the operation.

Listening to recorded messages from a remote location

- 1** Call your unit from a remote touch tone telephone.
- 2** Press **[*]** and the desired mailbox number (**[1]** or **[2]**) during TAD/FAX greeting playback.
 - If you have recorded your own mailbox greeting message, it will be played.
- 3** Enter the mailbox password (default setting "555").
 - If you have programmed your own mailbox password, enter it instead of "555".

Note:

- For details on remote operation, see page 77 to page 78.
[8][1], **[8][2]**, **[8][3]**, and **[8][4]** cannot be used.

To listen to messages in another memory after playback

Press **[*]** and **[0]** (for the common memory), then enter the remote operation ID.

or

Press **[*]** and the desired mailbox number (**[1]** or **[2]**), then enter the mailbox password.

Transferring recorded messages to another telephone

This feature allows your unit to call a designated telephone number each time an incoming voice message is recorded. You can retrieve the transferred message during the same call using the remote operation.

Important:

- To use this feature, program the transfer telephone number first (feature #60, page 91) and set the unit to TAD/FAX mode.

How this feature works

- 1 An incoming voice message is recorded in your unit.
- 2 Your unit calls the transfer telephone number.
- 3 Answer the call with the transfer telephone.
- 4 Your unit will play the pre-recorded transfer greeting message.
 - You can record your own transfer greeting message.
- 5 Enter the remote operation ID, and retrieve the message using the remote operation (page 77 to page 78).

Recording your own transfer greeting message

The recording time is limited to 16 seconds.

Suggested message: "This is a transferred message from (your name, business and/or telephone number). Please enter your remote ID for remote operation."

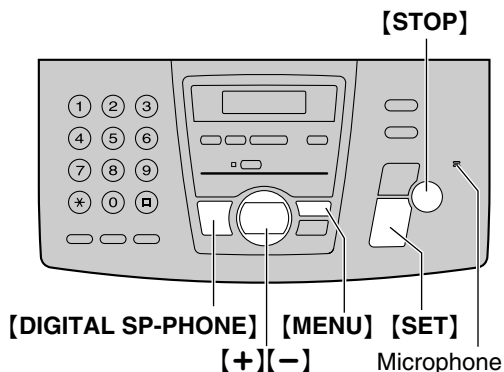

- 1 Press **[MENU]**.

SYSTEM SET UP PRESS NAVI. [◀ ▶]

- 2 Press **[#]**, then **[6][1]**.

TRNS-GREETING CHECK [±]

- 3 Press **[+]** or **[-]** to select "RECORD".

TRNS-GREETING RECORD [±]

- 4 Press **[SET]**.
- 5 Speak clearly about 20 cm (8 inches) away from the microphone.
 - The display will show the remaining recording time.

TRNS REC. 16s

- 6 When finished recording, press **[STOP]**.
 - The unit will repeat your message.
Adjust the volume using **[+]** or **[-]**.
- 7 Press **[MENU]**.

To check the transfer greeting message

1. Press **[MENU]**, **[#][6][1]**.
2. Press **[+]** or **[-]** to select "CHECK".
3. Press **[SET]**.
 - The unit will play the message.
4. Press **[MENU]**.

To erase your own transfer greeting message

1. Press **[MENU]**, **[#][6][1]**.
2. Press **[+]** or **[-]** to select "ERASE".
3. Press **[SET]**.
 - Your own message will be erased.
4. Press **[MENU]**.

Note:

- When transferring a call, the pre-recorded transfer greeting message will be played.

Pager call - when the unit receives a voice message

This feature allows your unit to call your pager when your unit receives an incoming voice message.

1. Press **[MENU]**.
2. Press **[#]**, then **[7][0]**.

PAGER CALL MODE=OFF [±]

3. Press **[+]** or **[-]** to select "ON".
 - If this feature is not required, select "OFF".
4. Press **[SET]**.
5. Enter your pager number up to 30 digits.
6. Press **[SET]**.
7. Enter your pager access code up to 10 digits if required.
8. Press **[SET]**.

MSG . = 07734

- The default code 07734 will show "Hello!" on your pager.
- If you want to change this message, enter your message up to 30 digits.

9. Press **[SET]**.

- The unit will dial the stored number.

10. Check that your pager received the pager test call.

11. Press **[DIGITAL SP-PHONE]**.

Note:

- If you have subscribed to a Caller ID service, instead of the message you entered in step 8, your pager will display the caller's telephone number.

Features Summary

Programming

The unit provides various programming features.

Programming method for basic features

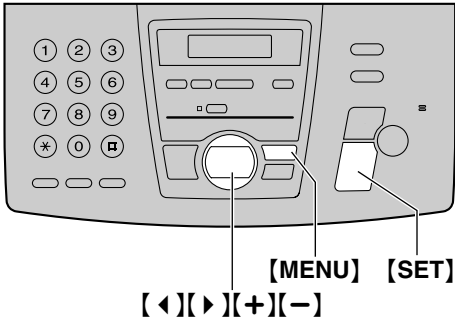

- 1 Press **[MENU]**.

SYSTEM SET UP
PRESS NAVI. [◀ ▶]

- 2 Select the feature you wish to program.
Press **[◀]** or **[▶]** until the desired feature is displayed.
 - The current setting of the feature will be displayed.
- 3 Press **[+]** or **[-]** until the desired setting is displayed.
 - This step may be slightly different depending on the feature.
- 4 Press **[SET]**.
 - The setting you selected is set, and the next feature will be displayed.
- 5 To exit programming, press **[MENU]**.

Programming by entering the program code number directly

You can select a feature by directly entering the program code (# and 2-digit number) instead of using **[◀]** or **[▶]**.

1. Press **[MENU]**.
2. Press **[#]** and the 2-digit code number (page 88).
3. Press **[+]** or **[-]** until the desired setting is displayed.
4. Press **[SET]**.
5. To exit programming, press **[MENU]**.

To cancel programming

Press **[MENU]** to exit the program.

Programming method for advanced features

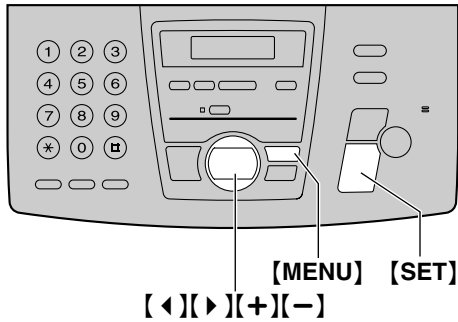

1 Press **[MENU]**.

SYSTEM SET UP
PRESS NAVI. [◀ ▶]

2 Press **[◀]** or **[▶]** until the following is displayed:

ADVANCED MODE
PRESS SET

3 Press **[SET]**.

4 Select the feature you wish to program.
Press **[◀]** or **[▶]** until the desired feature is displayed.

- The current setting of the feature will be displayed.

5 Press **[+]** or **[-]** until the desired setting is displayed.

- This step may be slightly different depending on the feature.

6 Press **[SET]**.

- The setting you selected is set, and the next feature will be displayed.

7 To exit programming, press **[MENU]**.

Programming by entering the program code number directly

You can select a feature by directly entering the program code (# and 2-digit number) instead of using **[◀]** or **[▶]**.

1. Press **[MENU]**.
2. Press **[#]** and the 2-digit code number (page 89 to page 92).
3. Press **[+]** or **[-]** until the desired setting is displayed.
4. Press **[SET]**.
5. To exit programming, press **[MENU]**.

To cancel programming

Press **[MENU]** to exit the program.

Features Summary

Basic features

Code #01: Setting the date and time

SET DATE & TIME PRESS SET

See page 31 for details.

Code #02: Setting your logo

YOUR LOGO PRESS SET

See page 32 for details.

Code #03: Setting your fax number

YOUR FAX NO. PRESS SET

See page 34 for details.

Code #04: Printing the sending report

SENDING REPORT MODE=ERROR [±]

To print and check the sending report for fax transmission results (page 56).

ERROR (default): The sending report will be printed only when fax transmission fails.

ON: The sending report will be printed out after every transmission.

OFF: The sending report will not be printed out.

Code #06: Changing the ring setting in TAD/FAX mode

TAD RING COUNT RINGS=2 [±]

To change the number of rings before the unit answers a call in TAD/FAX mode. You can select from **1**, **2 (default)**, **3**, **4**, “**TOLL SAVER**” and “**RINGER OFF**”. See page 65 for details.

Code #06: Changing the ring setting in FAX ONLY mode

FAX RING COUNT RINGS=3 [±]

To change the number of rings before the unit answers a call in FAX ONLY mode. You can select from **1**, **2**, **3 (default)** and **4**.

Code #10: Changing the incoming message recording time

RECORDING TIME MODE=VOX [±]

VOX (default): Unlimited.

1 MIN: Up to 1 minute.

Code #11: Setting the remote operation ID

REMOTE TAD ID ID=111

1. Press **[MENU]**.
2. Press **[◀]** or **[▶]** and select this feature.
3. Enter any 3-digit number except a number using 0 or 7.
 - The default ID is “**111**”.
4. Press **[SET]**.
5. Press **[MENU]**.

Code #13: Setting the dialing mode

DIALING MODE MODE=TONE [±]

If you cannot dial, change this setting depending on your telephone line service.

TONE (default): For tone dial service.

PULSE: For rotary pulse dial service.

Code #16: Setting the recording paper size

PAPER SIZE =LETTER [±]

LETTER (default): Letter or legal size paper.

A4: A4 size paper.

Code #17: Setting the ringer pattern

RINGER PATTERN MODE=A [±]

You can select from **A (default)**, **B** and **C**. The selected ringer pattern will sound during setting.

Advanced features

Code #22: Setting the journal report to print automatically

AUTO JOURNAL MODE=ON [±]

ON (default): The unit will print the journal report automatically after every 30 new fax communications (page 56).

OFF: The unit will not print the journal report, but keep records of the last 30 fax communications.

Code #23: Sending documents overseas

OVERSEAS MODE MODE=ERROR [±]

If you have difficulty sending an overseas fax, activate this feature before starting transmission. This feature makes sending documents easier as the transmission speed is slowed down.

- This feature is not available for broadcast transmission.
- The calling charge may be higher.

NEXT FAX: This setting is effective only for the next attempted fax transmission. After transmission, the unit will return to the previous setting.

ERROR (default): When the previous fax transmission fails and you wish to redial the same number.

OFF: Deactivates this feature.

Code #25: Sending a fax at a specific time

DELAYED SEND MODE=OFF [±]

This feature allows you to take advantage of low-cost calling hours offered by your telephone company. This feature can be set up to 24 hours in advance of the desired time.

To send a document:

1. Insert the document.
2. Press **[MENU]**.
3. Press **[⇄]**, then **[2][5]**.
4. Press **[+]** or **[-]** to select "ON".
5. Press **[SET]**.
6. Enter the fax number.
7. Press **[SET]**.
8. Enter the transmission start time.
 - Press **[*]** to select "AM" or "PM".
9. Press **[SET]**.

10. Press **[MENU]**.

- To cancel after programming, press **[STOP]** then **[SET]**.
- Turn on the auto answer setting.

Code #26: Setting the Caller ID list to print automatically

AUTO CALL. LIST MODE=ON [±]

ON (default): The unit will print the Caller ID list automatically after every 30 new calls (page 49).

OFF: The unit will not print the Caller ID list, but keep records of the last 30 caller information.

Code #31: Activating the Distinctive Ring feature

DISTINCTIVE RING MODE=OFF [±]

See page 66 for details.

Code #32: Setting the ring pattern for fax (Distinctive Ring feature)

FAX RING PATTERN RING=B-D [±]

See page 67 for details.

Code #34: Setting the quick scan

QUICK SCAN MODE=OFF [±]

This feature is helpful when you want to remove the document for other uses, because the unit will release the document before sending/copying.

- If the document exceeds the memory capacity, sending of the whole document or copying of the exceeded document will be canceled and this feature will be turned off automatically.

ON: The unit will scan the document and store it into memory first, then the unit will start sending/copying.

OFF (default): Deactivates this feature.

Features Summary

Code #36: Receiving oversized documents

RCV REDUCTION
MODE=92% [±]

If the size of the document sent by the other party is as large as, or larger than the recording paper, the unit can reduce the document and print it. Select the desired reduction rate.

Setting	Recording paper size	Original document size
100%	Legal	Letter, A4
	A4	Letter
92% (default)	Letter	Letter
	Legal	Legal
	A4	A4
86%	Letter	A4
72%	Letter	Legal
	A4	Legal

Code #39: Changing the display contrast

LCD CONTRAST
MODE=NORMAL [±]

NORMAL (default): For normal contrast.

DARKER: Used when the display contrast is too light.

Code #41: Changing the fax activation code

FAX ACTIVATION
MODE=ON [±]

If you use an extension telephone and wish to use it to receive a fax, activate this feature and program the activation code.

1. Press **[MENU]**.
2. Press **[±]**, then **[4][1]**.
3. Press **[+]** or **[-]** to select "ON".
4. Press **[SET]**.
5. Enter your code from 2 to 4 digits, using 0–9, # and *.
 - The default code is "*#9".
 - Do not enter "0000".
6. Press **[SET]**.
7. Press **[MENU]**.

Code #42: Setting the message alert

MESSAGE ALERT
MODE=OFF [±]

To alert you with beeps when a new voice message is recorded. If you hear slow beeps, listen to recorded messages. The beeps will stop.

ON: You will hear a beeping sound.

OFF (default): Deactivates this feature.

Code #43: Setting the recording time alert

REC. TIME ALERT
MODE=OFF [±]

To alert you with beeps when there is less than 60 seconds of remaining recording time. If you hear slow beeps, erase the recorded messages (page 75, 80). The beeps will stop.

ON: You will hear a beeping sound.

OFF (default): Deactivates this feature.

Code #44: Setting the memory reception alert

RECEIVE ALERT
MODE=ON [±]

To alert you with a beeping sound when a received fax document is stored into memory due to some existing problem.

If you are alerted by a slow beeping sound, clear the printing problem and make sure the unit is supplied with enough paper to print the stored document. The beeps will stop.

ON (default): You will hear a beeping sound.

OFF: Deactivates this feature.

Code #46: Setting the friendly reception

FRIENDLY RCV
MODE=ON [±]

To receive a fax automatically when you answer a call and hear a fax calling tone (slow beep).

ON (default): You do not have to press **[FAX/START]** for fax reception.

OFF: You have to press **[FAX/START]** for fax reception.

Features Summary

Code #47: Setting the fax voice guidance

FAX GUIDANCE MODE=ON [±]

If you wish to hear voice guidance, activate this feature.

ON (default): You will hear voice guidance.

OFF: Deactivates this feature.

ERROR: To hear the voice guidance only when fax transmission/reception fails.

Code #51: Setting the mailbox 1 password

BOX1 PASSWORD ID=

If you wish to prevent other users from retrieving messages, program a password for mailbox 1.

1. Press **[MENU]**.
2. Press **[#]**, then **[5][1]**.
3. Enter a 3-digit number except a number using digits 0 or 7.
 - The default ID is "555".
4. Press **[SET]**.
5. Press **[MENU]**.

Code #52: Setting the mailbox 2 password

BOX2 PASSWORD ID=

If you wish to prevent other users from retrieving messages, program a password for mailbox 2.

1. Press **[MENU]**.
2. Press **[#]**, then **[5][2]**.
3. Enter a 3-digit number except a number using digits 0 or 7.
 - The default ID is "555".
4. Press **[SET]**.
5. Press **[MENU]**.

Code #54: Changing the recording time for your own TAD/FAX greeting message

GREETING TIME MODE=16s [±]

16s (default): Up to 16 seconds.

60s: Up to 60 seconds.

See page 71 for details.

Code #55: Greeting message for mailbox 1

BOX1 GREETING CHECK [±]

See page 80 for details.

Code #56: Greeting message for mailbox 2

BOX2 GREETING CHECK [±]

See page 80 for details.

Code #60: Setting the message transfer

MESSAGE TRANSFER MODE=OFF [±]

To transfer a recorded incoming message to another telephone (page 84), activate this feature and program the transfer telephone number.

1. Press **[MENU]**.
2. Press **[#]**, then **[6][0]**.
3. Press **[+]** or **[-]** to select "ON".
4. Press **[SET]**.
5. Enter the transfer telephone number.
6. Press **[SET]**.
7. Press **[MENU]**.

Code #61: Checking, recording or erasing the transfer greeting message

TRNS-GREETING CHECK [±]

See page 84, 85 for details.

Code #67: Setting the incoming message monitor

ICM MONITOR MODE=ON [±]

To hear an incoming message (ICM) from the speaker when the answering device is recording the message.

ON (default): You can monitor the incoming message.

OFF: Deactivates this feature.

Code #70: Calling your pager

PAGER CALL MODE=OFF [±]

See page 85 for details.

Features Summary

Code #76: Setting the connecting tone

CONNECTING TONE MODE=ON [±]

If you often have trouble when sending a fax, this feature allows you to hear connecting tones; fax tone, ring back tone and busy tone. You can confirm the status of the other party's machine.

- If the ring back tone continues, the other party's machine may not be a facsimile or may have run out of paper. Check with the other party.
- The connecting tone volume cannot be adjusted.

ON (default): You will hear connecting tones.

OFF: Deactivates this feature.

Code #77: Changing the receiving mode in the auto answer setting

AUTO ANSWER MODE=TAD/FAX [±]

TAD/FAX (default): Telephone Answering Device/Facsimile mode (page 64)

FAX ONLY: Facsimile only mode (page 64)

Code #80: Resetting advanced features to their default settings

SET DEFAULT RESET=NO [±]

To reset the advanced features:

1. Press **[MENU]**.
2. Press **[⇄]**, then **[8][0]**.
3. Press **[+]** or **[-]** to select "YES".
4. Press **[SET]**.
5. Press **[SET]** again.
6. Press **[MENU]**.

Reports

If your unit cannot send a fax, check the following:

- The number you dialed is correct.
- The other party's machine is a fax machine.

If the problem remains, correct it by following the communication message printed on the sending and journal reports (page 56).

COMMUNICATION ERROR

(Code: 40-42, 46-72, FF)

- A transmission or reception error occurred.
Try again or check with the other party.

COMMUNICATION ERROR

(Code: 43, 44)

- A line problem occurred. Connect the telephone line cord to a different jack and try again.
- An overseas transmission error occurred. Try using the overseas mode of feature #23 (page 89).

DOCUMENT JAMMED

- The document is jammed. Remove the jammed document (page 106).

ERROR-NOT YOUR UNIT

(Code: 54, 59, 70)

A transmission or reception error occurred because of a problem with the other party's fax machine. Check with the other party.

MEMORY FULL

- The document was not received as a result of the memory being full.

NO DOCUMENT

- The document was not fed into the unit properly. Reinsert the document and try again.

OTHER FAX NOT RESPONDING

- The other party's fax machine is busy or has run out of recording paper. Try again.
- The document was not fed properly. Reinsert the document and try again.
- The other party's fax machine rings too many times. Send the fax manually (page 55).
- The other party's machine is not a fax machine. Check with the other party.
- The number you dialed is not in service.

PRESSED THE STOP KEY

- **[STOP]** was pressed and fax communication was canceled.

OK

- Fax communication was successful.

Error Messages

Display

If the unit detects a problem, one or more of the following messages will appear on the display.

Base unit

CALL SERVICE

- There is something wrong with the unit. Contact our service personnel.

CHECK DOCUMENT

- The document was not fed into the unit properly. Reinsert the document. If misfeeding occurs frequently, clean the document feeder rollers (page 108) and try again.
- Attempted to transmit a document longer than 600 mm. Press **[STOP]** to remove the document. Divide the document into two or more sheets and try again.

CHECK MEMORY

- The memory (telephone numbers, parameters, etc.) has been erased. Re-program.

CHECK PAPER

- The recording paper is not installed or the unit has run out of paper. Install paper and press **[SET]** to clear the message. To continue copying, try again (page 68).
- The recording paper was not fed into the unit properly (page 105). Reinstall paper (page 18) and press **[SET]** to clear the message.
- The recording paper has jammed near the recording paper entrance. Clear the jammed paper (page 103) and press **[SET]** to clear the message. Do not install folded or heavily curled paper.

COVER OPEN



CHECK FILM

- The covers are open. Close them.
- The ink film is empty. Replace the ink film with a new one (page 101).
- The ink film is not installed. Install it (page 14).
- The ink film is slack. Tighten it (see step 7 on page 102).

DIRECTORY FULL

- There is no space to store new entries in navigator directory. Erase unnecessary entries (page 45).

FAX IN MEMORY

- The unit has a document in memory. See the other displayed message instructions to print out the document.

FAX MEMORY FULL

- The memory is full of received documents due to a lack of recording paper or a recording paper jam. Install paper (page 18) or clear the jammed paper (page 103).
- When performing memory transmission, the document being stored exceeds the memory capacity of the unit. Transmit the entire document manually.

MEMORY FULL

- When making a copy, the document being stored exceeds the memory capacity of the unit. Press **[STOP]** to clear the message. Divide the document into sections.

MESSAGE FULL

- There is no room left in memory to record a voice message. Erase unnecessary messages (page 75, 76, 81).

MODEM ERROR

- There is something wrong with the modem circuit. Contact our service personnel.

NO FAX REPLY

- The other party's fax machine is busy or has run out of recording paper. Try again.

PAPER JAMMED

- A recording paper jam occurred. Clear the jammed paper (page 103).

PLEASE WAIT

- The unit is checking that there is no slack on the ink film. Wait for a moment while the check is completed.

REDIAL TIME OUT

- The other party's fax machine is busy or has run out of recording paper. Try again.

REMOVE DOCUMENT

- The document is jammed. Remove the jammed document (page 106).

TRANSMIT ERROR

- A transmission error occurred. Try again.

UNIT OVERHEATED

- The unit is too hot. Let the unit cool down.

Handset

Directory full

- There is no space to store new entries in the navigator directory. Erase unnecessary entries (page 45).

No link to base Place on cradle and try again.

- The handset has lost communication with the base unit. Move closer and try again.
- Place the handset on the base unit and try again.
- The power cord is disconnected. Plug in the power cord.

Not available

- [**▶**], [**▲**], [**▼**], [**FLASH**], [**CALL WAIT/PLAYBACK**], [**CLEAR**], [**HOLD**] or [**INTERCOM**] was pressed while the base unit was in use.

Please lift up and try again.

- A key was pressed while the handset was on the base unit. Lift the handset and press the button again.

Save error

- While programming, the handset has lost communication with the base unit. Move closer to the base unit.

Frequently Asked Questions

When a function does not work, check here

General

I cannot make and receive calls.

- The power cord or telephone line cord is not connected. Check the connections.
- If you used a splitter to connect the unit, remove the splitter and connect the unit to the wall jack directly. If the unit operates properly, check the splitter.

I cannot make calls.

- The dialing mode setting is wrong. Change the setting of feature #13 (page 88).

The unit does not work.

- Disconnect the unit from the telephone line and connect the line to a known working telephone. If the working telephone operates properly, contact our service personnel to have the unit repaired. If the working telephone does not operate properly, contact your telephone company.

The unit does not ring.

- The ringer volume is set to off. Adjust it (page 29, 30).
- The ring setting of feature #06 is set to "RINGER OFF". Change to another ring setting (page 88).

The unit displays the following though the paper is inserted.

CHECK PAPER

- The paper is inserted halfway. Insert it correctly (page 18) and press **[SET]** to clear the message.

The other party complains they only hear a fax tone and cannot talk.

- FAX ONLY mode is set. Tell the other party the number is only used for faxes.
- Change to TEL mode or TAD/FAX mode by pressing **[AUTO ANSWER]**.
- If you use a Distinctive Ring service, turn AUTO ANSWER off so that the fax machine is in TEL mode.

- If you use a Distinctive Ring service, make sure you have set the same ring pattern assigned by the telephone company (page 66).

The receiving mode does not function properly.

- Distinctive Ring feature #31 is set (page 89).

The **[REDIAL/PAUSE]** button does not function properly.

- If this button is pressed during dialing, a pause will be inserted. If pressed immediately after a dial tone is obtained, the last number dialed will be redialed.

During programming, I cannot enter the code or ID number.

- All or part of the numbers are the same. Change the number: feature #11 (page 88), #41 (page 90), #51 and #52 (page 91).

The ink film runs out quickly.

- The help printing function, copy function, and reports also use ink film.

The unit beeps.

- Recording paper or ink film has run out. Press **[STOP]** to stop the beeps and install paper/ink film.

Whenever I try to retrieve my Voice Mail messages, the retrieval is interrupted by the fax tone.

- You are probably entering ✕#9. This is the default setting for the fax activation code. If you use a Voice Mail service, set the fax activation feature to off or reprogram the activation code (feature #41, page 90).

The speakerphone is not working.

- Use the speakerphone in a quiet room.
- If you have difficulty hearing the other party, adjust the volume.

The **[LOCATOR/INTERCOM]** button does not function.

- The handset is too far from the base unit.
- The handset is engaged in an outside call.

Frequently Asked Questions

While having an intercom call, the intercom call stops and the unit starts to ring.

- Someone is calling you from outside. Press **[TALK]**, **[SP-PHONE]** or **[DIGITAL SP-PHONE]** to answer the outside call.

Cordless handset

The handset does not work.

- Make sure that the battery is installed correctly (page 107).
- Charge the battery fully (page 21).
- Clean the charge contacts and charge again (page 21).

The handset does not ring.

- The ringer volume is set to off. Adjust it (page 29).

The display shows the following and an alarm tone sounds when I press [TALK], [CLEAR], [HOLD], [INTERCOM], [FLASH] or [CALL WAIT/PLAYBACK].

No link to base
Place on cradle
and try again.

- The handset is too far from the base unit. Move closer and try again.
- Place the handset on the base unit and try again.
- The power cord is disconnected. Plug in the power cord.

Static, sound cuts in/out, fades. Interference from other electrical units.

- Locate the handset and the base unit away from other electrical appliances.
- Move closer to the base unit.
- Press **[◀]** on the handset to select a clearer channel.
- Raise the base unit antenna.

The handset stops working while being used.

- Place the handset on the base unit, and disconnect the power cord to reset the unit. Connect the power cord, and try again.

I cannot store a name and telephone number in the navigator directory.

- You cannot store a name and number while the unit is in the talk or intercom mode.
- Do not pause for over 60 seconds while storing.

While storing a name and telephone number in the navigator directory, the handset starts to ring.

- To answer a call, press **[TALK]** or **[SP-PHONE]**. The program will be canceled. Store the name and number again.

I cannot redial by pressing [REDIAL].

- If the last number dialed was more than 32 digits long, the number will not be redialed.

The handset beeps intermittently and/or the following is displayed.

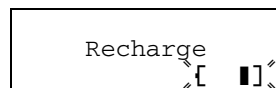

- Charge the battery fully (page 21).

I charged the battery fully, but the following is still displayed:

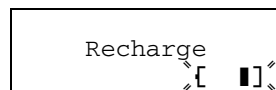

- Clean the charge contacts and charge again (page 21).
- It is time to replace the battery (page 107).

I cannot receive documents by pressing ✕#9 on the handset.

- You must set the remote fax activation to on (feature #41, page 90) beforehand.
- Press **✕#9** firmly. A single beep will be heard.
- The memory is full of received documents due to a lack of recording paper or a recording paper jam. Install paper or clear the jammed paper.

The handset display is blank.

- Charge the battery fully (page 21).

The handset display exits the Caller ID List while viewing the caller information.

- Do not pause for over 60 seconds while searching.

Frequently Asked Questions

Fax – sending

I cannot send documents.

- The other party's fax machine is busy or has run out of recording paper. Try again.
- The other party's machine is not a fax machine. Check with the other party.
- The other party's fax machine rings too many times. Send the fax manually (page 55).

The other party complains that letters on their received document are distorted or not clear.

- If your line has special telephone services such as Call Waiting, the service may have been activated during fax transmission. Connect the unit to a line that does not have these services.
- The extension telephone on the same line is off the hook. Hang up the extension telephone and try again.
- Try copying the document. If the copied image is clear, there may be something wrong with the other party's machine.

The other party complains that smudges or black lines appear on their received document.

- The glass or rollers are dirty. Clean them (page 108).

I cannot send a fax overseas.

- Use the overseas transmission mode of feature #23 (page 89).
- Add two pauses at the end of the telephone number or dial manually.

Fax – receiving

I cannot receive documents.

- When you have a single telephone line and subscribe to a Voice Mail service, you must also subscribe to a Distinctive Ring service (page 66).

I cannot receive documents automatically.

- The receiving mode is set to TEL mode. Set to TAD/FAX mode or FAX ONLY mode by pressing **[AUTO ANSWER]**.
- The time taken to answer the call is too long. Decrease the number of rings of feature #06 (page 88).
- The greeting message is too long. Shorten the message (page 71).

The display shows the following, but faxes are not received.

CONNECTING

- The incoming call is not a fax. Change the receiving mode to TAD/FAX mode or TEL mode by pressing **[AUTO ANSWER]**.

A blank sheet is ejected.

- If a blank sheet is ejected after the received document is printed out, the receiving reduction rate is not programmed correctly. Program the proper rate in feature #36 (page 90).
- The other party placed the document in their fax machine the wrong way. Check with the other party.

A white line or a smudge appears on your recording paper.

- The glass or rollers are dirty. Clean them (page 108).

The printing quality is poor.

Note:

Please do not reuse the ink film!

Please use genuine Panasonic replacement film. Refer to page 10 for further details.

- The other party sent a faint document. Ask them to send a clearer copy of the document.
- The thermal head is dirty. Clean it (page 109).
- Some paper has instructions recommending which side to print on. Try turning the paper over.

Frequently Asked Questions

- You may have used paper with a cotton and/or fiber content that is over 20%, such as letterhead or resume paper. We recommend smooth paper such as “Hammermill Jet Print” for clearer printing.

I cannot receive documents by pressing ✕#9 on the handset.

- You must set the remote fax activation to on (feature #41, page 90) beforehand.
- Press ✕#9 firmly. A single beep will be heard.
- The memory is full of received documents due to a lack of recording paper or a recording paper jam. Install paper or clear the jammed paper.

The other party complains that they cannot send a document.

- The memory is full of received documents due to a lack of recording paper or a recording paper jam. Install paper (page 18) or clear the jammed paper (page 103).

Receiving mode

I cannot select the desired receiving mode.

- If you want to set TAD/FAX or FAX ONLY mode:
 - select the desired mode using feature #77 (page 92), and
 - press **[AUTO ANSWER]** repeatedly until the desired mode is displayed.
- If you want to set TEL mode:
 - press **[AUTO ANSWER]** repeatedly until TEL mode is displayed.

The other party complains that they cannot send a document.

- The unit is not in TAD/FAX or FAX ONLY mode. Select the desired mode using feature #77 and press **[AUTO ANSWER]** repeatedly until TAD/FAX or FAX ONLY mode is displayed.

Copying

The unit does not make a copy.

- You cannot make a copy during programming. Make the copy after programming or stop programming.
- You cannot make a copy during telephone conversation.

A black line, a white line or smudge appears on the copied document.

- The glass or rollers are dirty. Clean them (page 108).

The copied image is distorted.

- The thermal head is dirty. Clean it (page 109).

The printing quality is poor.

Note:

Please do not reuse the ink film!

Please use genuine Panasonic replacement film. Refer to page 10 for further details.

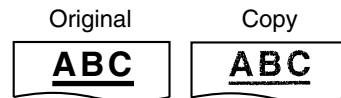

- Some paper has instructions recommending which side to print on. Try turning the paper over.
- You may have used paper with a cotton and/or fiber content that is over 20%, such as letterhead or resume paper. We recommend smooth paper such as “Hammermill Jet Print” for clearer printing.

Frequently Asked Questions

Answering device

I cannot retrieve recorded messages from a remote location.

- Press the remote operation ID correctly and firmly (page 77).

Messages in the mailbox do not play back.

- The mailbox password is wrong. Enter the correct password.
 - For mailbox 1 password, see feature #51 (page 91).
 - For mailbox 2 password, see feature #52 (page 91).

The other party complains that they cannot leave a voice message.

- The memory is full. Erase unnecessary messages (page 75, 76, 81).

While operating the answering device from the handset, the remote operation stops and the unit starts to ring.

- Someone is calling you from outside.
Press **[TALK]** or **[SP-PHONE]** to answer the outside call.

I cannot operate the answering device with the handset.

- Someone is operating the answering device.
- You are too far from the base unit. Move closer to the base unit.

If a power failure occurs

- The unit will not function.
- The unit is not designed for making emergency telephone calls when the power fails. Alternative arrangements should be made for access to emergency services.
- Fax transmission and reception will be interrupted.
- If the delayed transmission (feature #25, page 89) is programmed and the start time is passed during a power failure, transmission will be attempted soon after power is restored.
- If any fax documents are stored in the memory, they will be lost. When power is restored, a power down report will be printed out stating which contents in the memory have been erased.

Ink film

Replacement film Model No. **KX-FA53 (1 roll)**, **KX-FA55 (2 rolls)** or **KX-FA55D (4 rolls)**: Each roll prints about 150 letter-sized pages. See page 10 for accessory information.

- 1** Open the front cover by pulling up the center part.

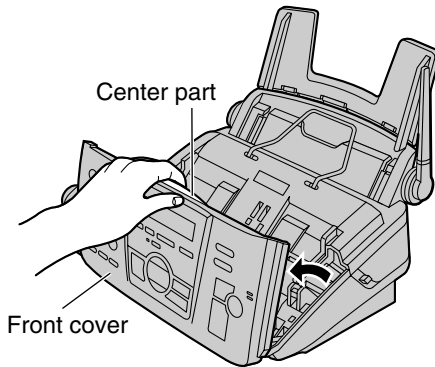

- 2** Release the back cover by pushing the back cover open button (green) on the right side of the unit.
OR
Release the back cover by pushing the back cover open lever (green) in the unit.

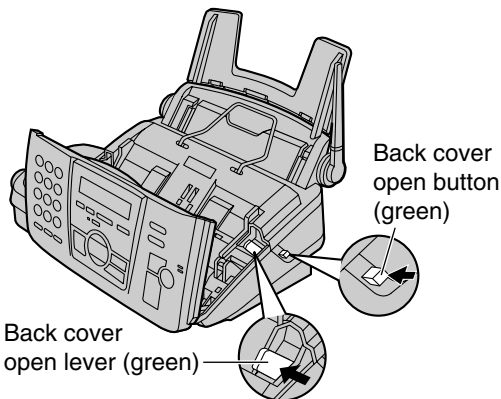

- 3** Open the back cover.

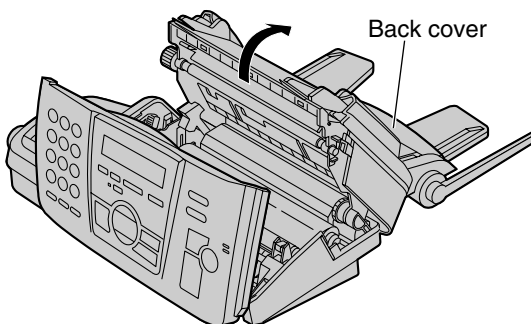

- 4** Pull out the blue gear and remove the used ink film. Remove the used core.

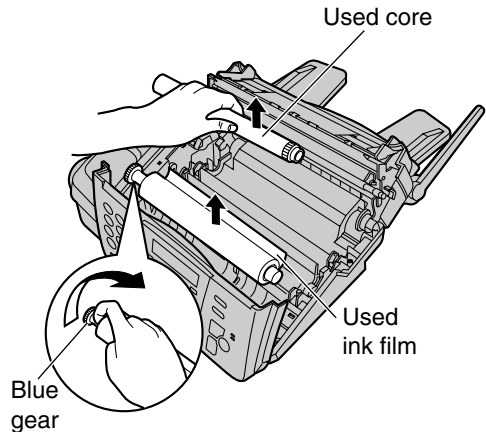

- 5** Remove the stoppers and tags from the new ink film. Find the "T" shaped gear (blue).

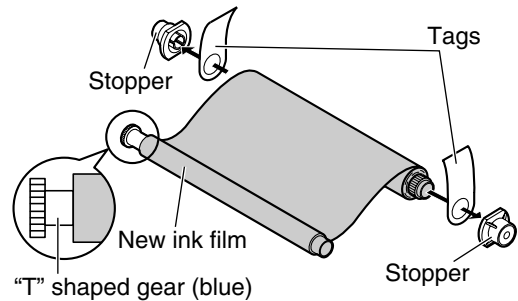

- 6** Insert the blue core of the front ink film roll into the right slot of the unit (①). Insert the "T" shaped gear (blue) into the left slot of the unit (②). Insert the rear ink film roll (③).

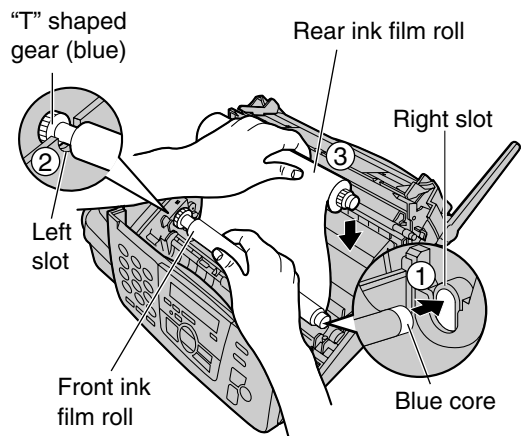

Replacement

- 7** Turn the “T” shaped gear (blue) in the direction of the arrow.

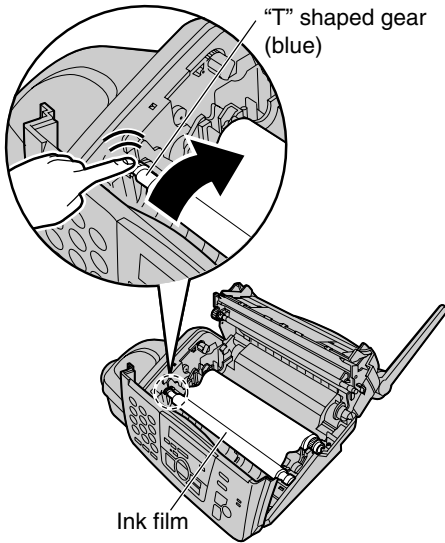

- Make sure that the ink film is wrapped around the blue core at least once.

Correct

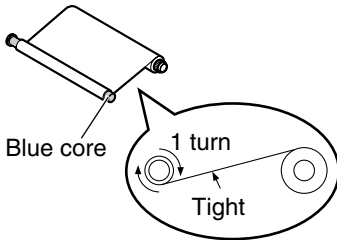

Incorrect

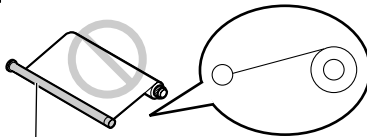

The ink film is not wrapped around the blue core.

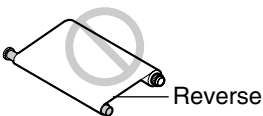
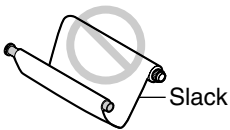

- 8** Close the back cover securely by pushing down on the dotted area at both ends (①). Close the front cover securely (②).

- The following message will be displayed while the unit is checking that there is no slack in the ink film.

PLEASE WAIT

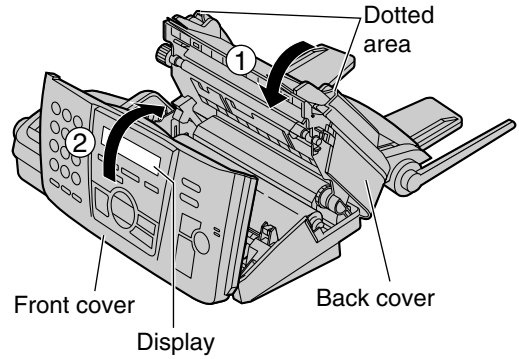

Note:

- The ink film is safe to touch, and will not rub off on your hands like carbon paper.

Recording paper jam

When the recording paper has jammed in the unit

The display will show the following.

PAPER JAMMED

- 1 Open the front cover by pulling up the center part.

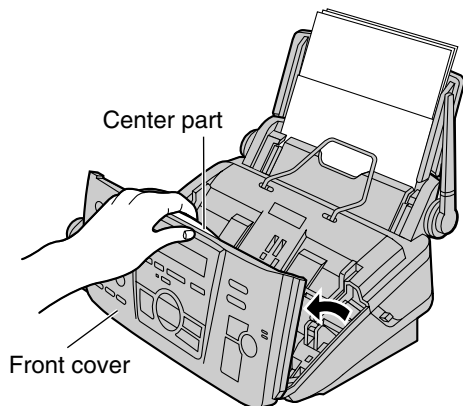

- 2 Release the back cover by pushing the back cover open button (green) on the right side of the unit.
OR
Release the back cover by pushing the back cover open lever (green) in the unit.

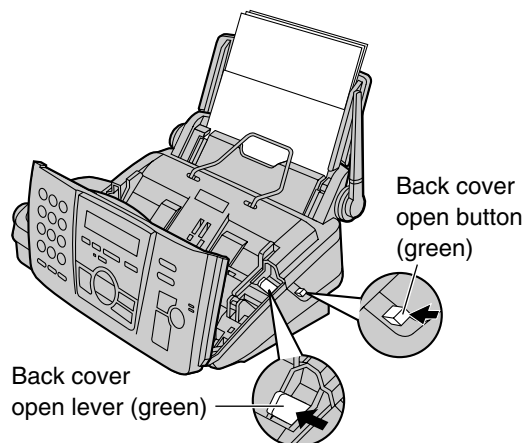

- 3 Open the back cover.

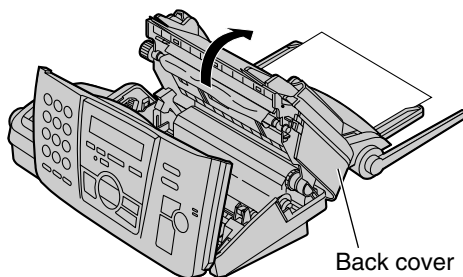

- 4 Remove the jammed recording paper.

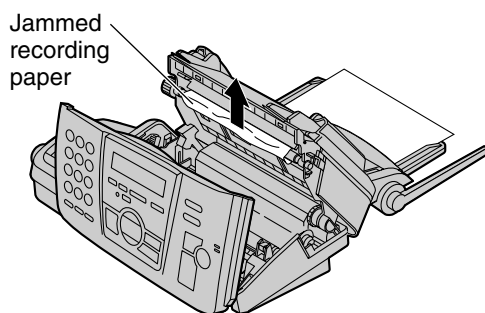

Jams

- 5** Turn the “T” shaped gear (blue) in the direction of the arrow.

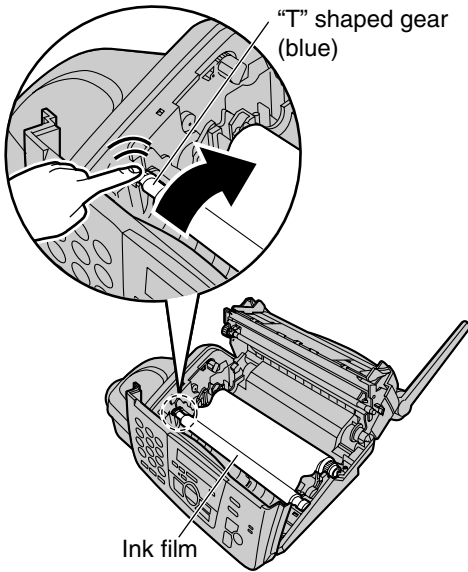

- Make sure that the ink film is wrapped around the blue core at least once.

Correct

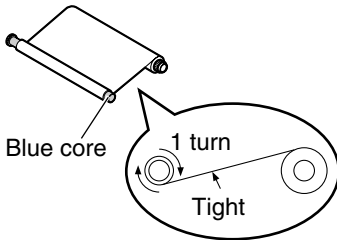

Incorrect

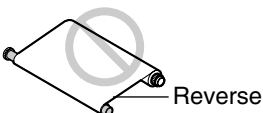
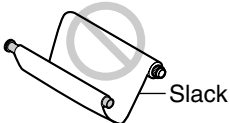
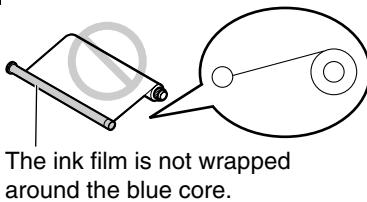

- 6** Close the back cover securely by pushing down on the dotted area at both ends (①). Close the front cover securely (②).

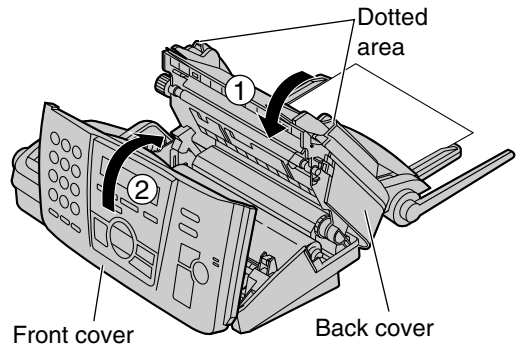

- 7** Remove the recording paper and straighten. Pull the tension plate forward and hold open while inserting the paper.

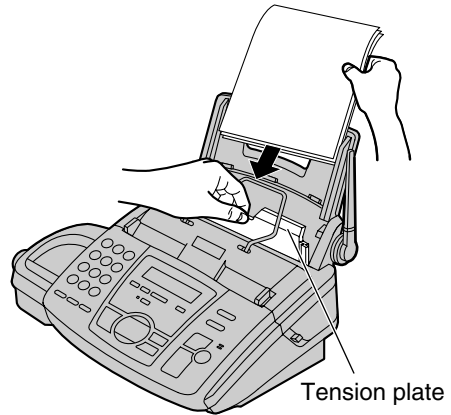

When the recording paper was not fed into the unit properly

The display will show the following.

CHECK PAPER

Remove the recording paper and straighten. Pull the tension plate forward and hold open while inserting paper.

Press **[SET]** to clear the message.

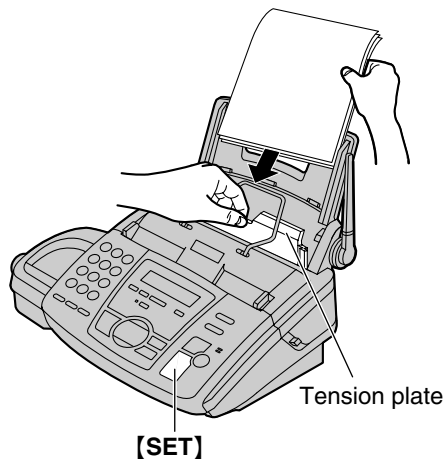

Document jams – sending

- 1 Open the front cover by pulling up the center part.
Remove the jammed document carefully.

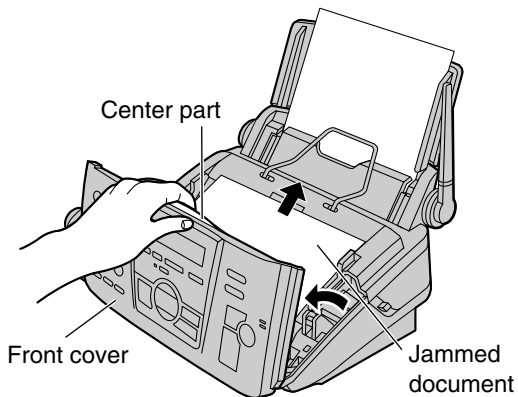

- 2 Close the front cover securely.

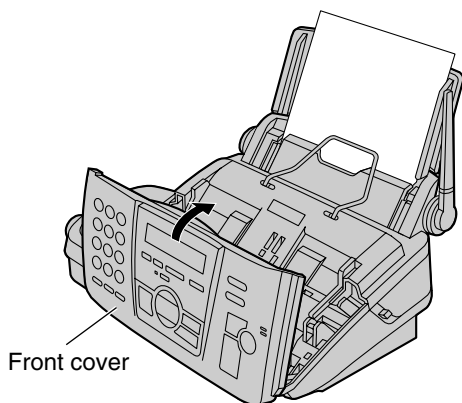

Note:

- Do not pull out the jammed paper forcibly before opening the front cover.

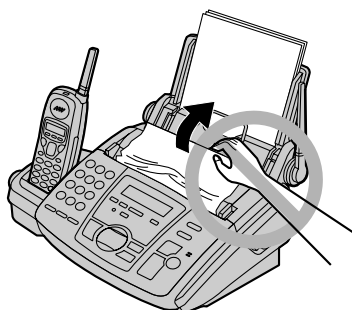

Replacing the handset battery

Replace the battery with a new **Panasonic rechargeable battery Model No. P-P511**. See page 10 for accessory information.

- 1** Press the notch on the handset cover firmly and slide it as indicated by the arrow.

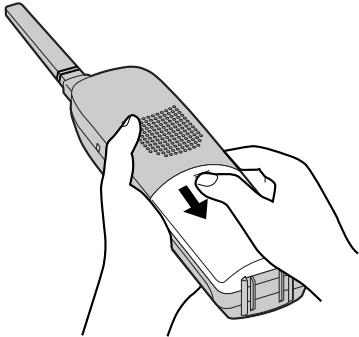

- 2** Remove the old battery. Insert the new battery into the handset as shown, matching the correct polarity (①). Press the battery down until it places into the compartment (②).

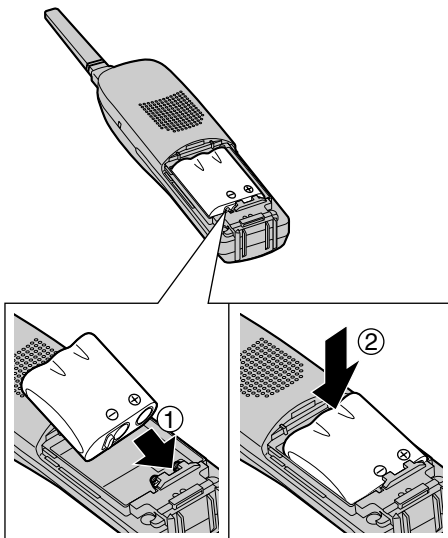

- 3** Close the cover. Make sure you charge the new battery for about 15 hours in order to display the battery strength prompt correctly (page 21).

Attention:



A recyclable nickel cadmium battery powers the product you have purchased.

At the end of its useful life, under various state and local laws, it is illegal to dispose of this battery into your municipal waste stream.

Please call 1-800-8-BATTERY for information on how to recycle this battery.

Cleaning

Document feeder

Clean the document feeder in the following cases:

- If misfeeding of the document occurs frequently.
- If smudges or black/white lines appear on the original document when transmitting or copying.

- 1** Disconnect the power cord and the telephone line cord.

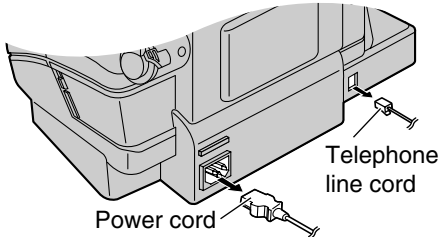

- 2** Open the front cover by pulling up the center part.

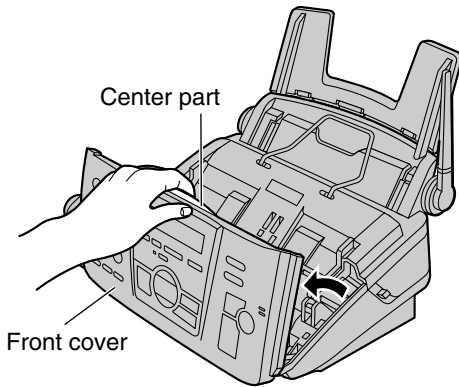

- 3** Clean the document feeder rollers and rubber flap with a cloth moistened with isopropyl rubbing alcohol, and let all parts dry thoroughly.

Caution:

- Do not use paper products, such as paper towels or tissues.

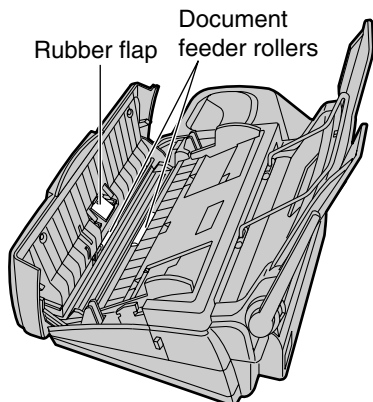

- 4** Clean the glass with a soft and dry cloth.

Caution:

- Do not use paper products, such as paper towels or tissues.

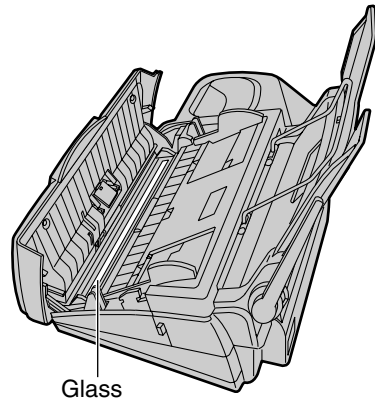

- 5** Close the front cover securely.

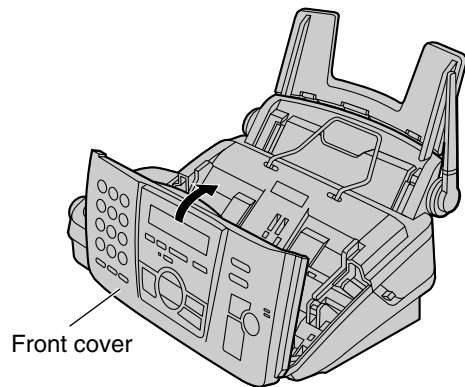

- 6** Connect the power cord and the telephone line cord.

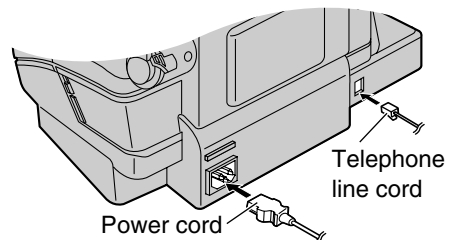

Thermal head

If smudges or black/white lines appear on a copied/received document, check whether there is dust on the thermal head. Clean the thermal head to remove the dust.

- 1** Disconnect the power cord and the telephone line cord.

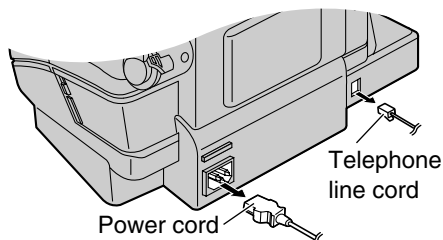

- 2** Open the front cover by pulling up the center part.

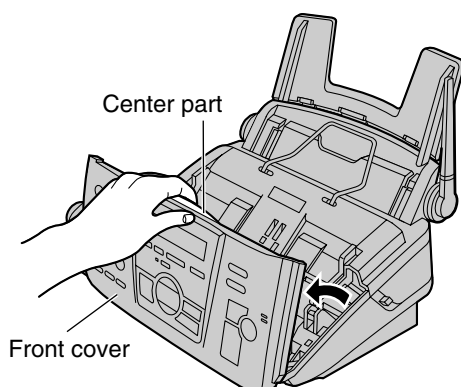

- 3** Release the back cover by pushing the back cover open button (green) on the right side of the unit.
OR
Release the back cover by pushing the back cover open lever (green) in the unit.

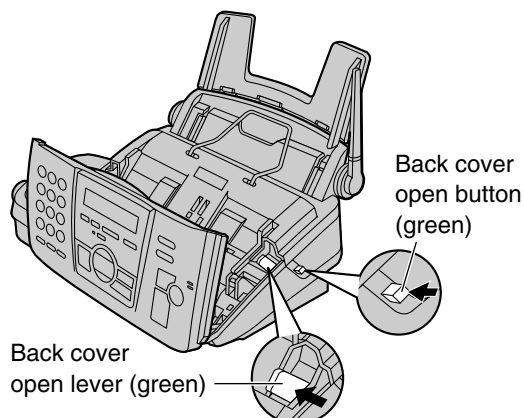

- 4** Open the back cover. Remove the ink film.

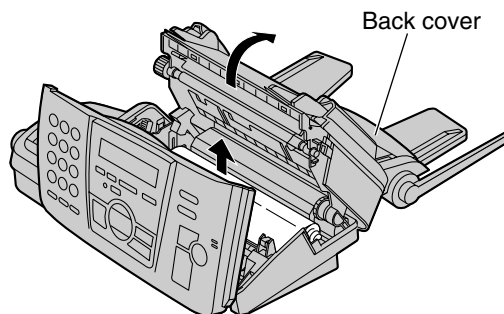

- 5** Clean the thermal head with a cloth moistened with isopropyl rubbing alcohol, and let it dry thoroughly.

Caution:

- To prevent a malfunction due to static electricity, do not use a dry cloth and do not touch the thermal head directly.

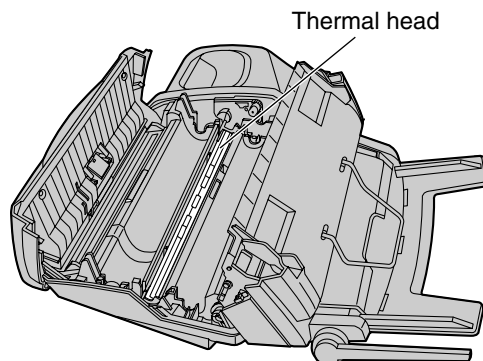

Cleaning

- 6** Replace the ink film.
Turn the "T" shaped gear (blue) in the direction of the arrow.

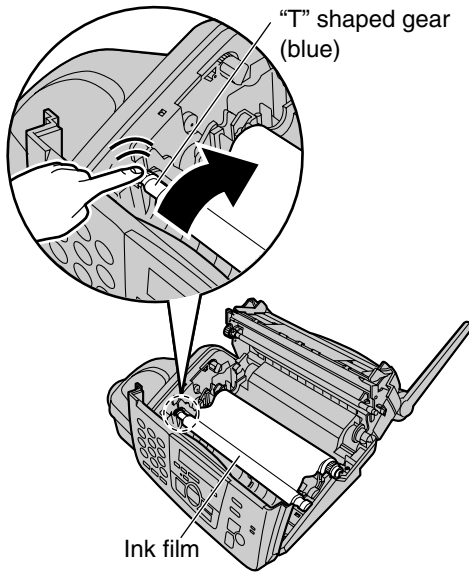

- Make sure that the ink film is wrapped around the blue core at least once.

Correct

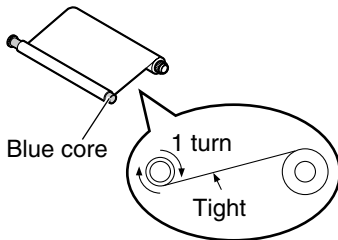

Incorrect

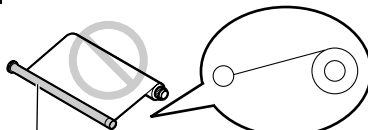

The ink film is not wrapped around the blue core.

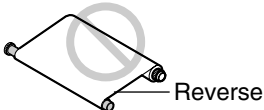
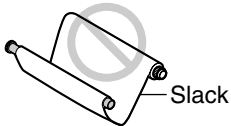

- 7** Close the back cover securely by pushing down on the dotted area at both ends (①).
Close the front cover securely (②).

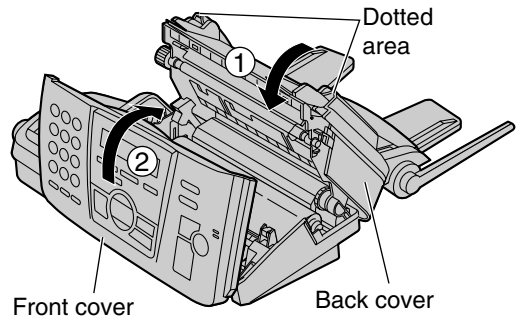

- 8** Connect the power cord and the telephone line cord.

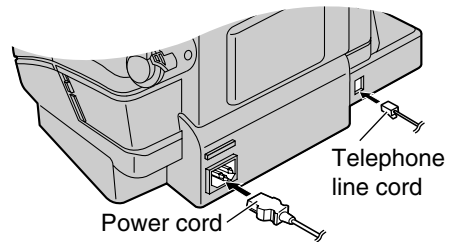

Reference lists and reports

You can print out the following lists and reports for your reference.

Setup list:

provides you with the current settings of the basic and advanced programming features (page 88 to page 92).

Telephone number list:

provides you with names and telephone numbers which are stored in the directory.

Journal report:

keeps records of fax transmission and reception. This report will be printed automatically after every 30 fax communications (feature #22, page 89).

Printer test:

allows you to check the print quality of your unit. If the test print has a smudge, or blurred points or lines, clean the thermal head (page 109).

Broadcast programming list:

provides you with entries which are stored in the broadcast feature (page 59).

Caller ID list:

keeps records of the last 30 callers after subscribing to a Caller ID service. This report will be printed automatically after every 30 callers (feature #26, page 89).

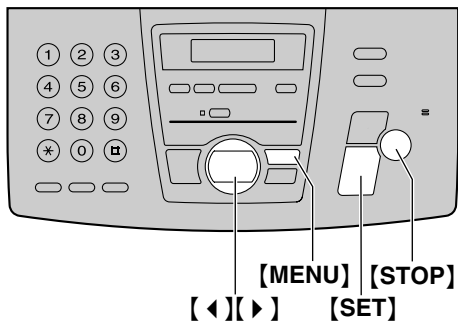

- 1** Press **[MENU]** repeatedly until the following is displayed.

```
PRINT REPORT  
PRESS NAVI. [◀ ▶]
```

- 2** Press **[◀]** or **[▶]** until the desired item is displayed.

```
SETUP LIST  
PRESS SET
```

```
TEL NO. LIST  
PRESS SET
```

```
JOURNAL REPORT  
PRESS SET
```

```
PRINTER TEST  
PRESS SET
```

```
BROADCAST LIST  
PRESS SET
```

```
CALLER ID LIST  
PRESS SET
```

- 3** Press **[SET]** to start printing.

```
PRINTING
```

- To stop printing, press **[STOP]**.
- After printing, the printed item will be displayed.

- 4** Press **[MENU]**.

Caller IQ Feature

openLCR service for the Caller IQ feature

This unit is compatible with service provided by openLCR.

- If you have any questions regarding the openLCR service, call openLCR's customer service department at 1-866-openLCR (1-866-673-6527).
- NEITHER KYUSHU MATSUSHITA ELECTRIC CO., LTD. (KME) NOR MATSUSHITA ELECTRIC CORPORATION OF AMERICA (MECA) IS IN ANY WAY AFFILIATED WITH, OR RESPONSIBLE FOR THE ACTS OR OMISSIONS OF, OPENLCR.COM, INC. (OPENLCR). NEITHER KME NOR MECA NOR ANY OF THEIR EMPLOYEES OR AFFILIATES OR CUSTOMERS MAKE ANY WARRANTIES OR REPRESENTATIONS, EITHER EXPRESS OR IMPLIED, TO ANY CUSTOMER OR ANY OTHER THIRD PARTY WITH RESPECT TO ANY OF THE SERVICES PROVIDED BY OPENLCR, NOR ASSUME NOR CREATE ANY OTHER OBLIGATION OF ANY KIND ON BEHALF OF OPENLCR.
- If you subscribe to openLCR service, the unit will start the first download of the rate table to your fax machine and the Caller IQ feature will be automatically turned on. The CALLER IQ indicator will stay on. No special dialing or button pressing is necessary to place a long distance call with the Caller IQ feature.

If you do not wish to use the Caller IQ feature, you can turn it off temporarily.

Note:

- Before subscribing to openLCR service, you cannot change the following settings.

To turn the Caller IQ feature from ON to OFF using the handset

4 Press [**#**].

Caller IQ off

- A beep sounds and Caller IQ function is set to OFF.
- If 3 beeps sound, Caller IQ is not set to OFF. Start again from step 1.



1 Press [**CALLER IQ**].

Press "1" or "#".
1: View Info.
#: Get new Info.

2 Press [**0**].

To disable
Caller IQ,
press 3, #.

3 Press [**3**].

To disable
Caller IQ,
press #.

Caller IQ Feature

To turn the Caller IQ feature from ON to OFF using the base unit

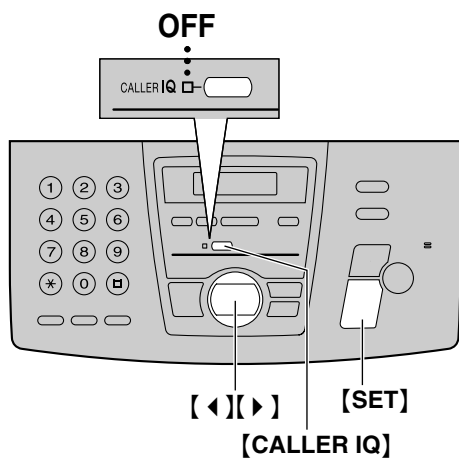

1 Press **[CALLER IQ]**.

CALLER IQ
PRESS NAVI. [◀ ▶]

2 Press **[◀]** or **[▶]** until the following is displayed or press **[0]**.

TO DISABLE IQ
PRESS "3", SET

3 Press **[3]**.

TO DISABLE IQ
PRESS SET

4 Press **[SET]**.

CALLER IQ OFF

- The CALLER IQ indicator will turn off.

To turn the Caller IQ feature from OFF to ON using the handset



1 Press **[CALLER IQ]**.

To enable
Caller IQ,
press 0,1,*.

2 Press **[0]**.

To enable
Caller IQ,
press 1,*.

3 Press **[1]**.

To enable
Caller IQ,
press *.

4 Press **[*]**.

Caller IQ on

- A beep sounds and Caller IQ function is set to ON.
- If 3 beeps sound, Caller IQ is not set to ON. Start again from step 1.
- In steps 1 through 3, if you do not press any buttons for 60 seconds or you press **[OFF]**, the handset will exit the programming mode.

Caller IQ Feature

To turn the Caller IQ feature from OFF to ON using the base unit

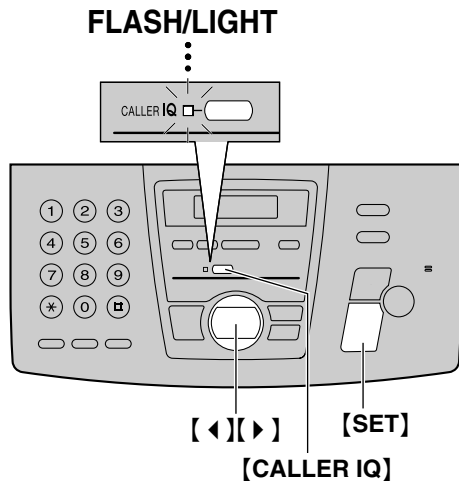

1 Press **[CALLER IQ]**.

```
CALLER IQ  
PRESS NAVI. [< >]
```

2 Press **[<]** or **[>]** until the following is displayed or press **[0]**.

```
TO ENABLE IQ  
PRESS "1", SET
```

3 Press **[1]**.

```
TO ENABLE IQ  
PRESS SET
```

4 Press **[SET]**.

```
CALLER IQ ON
```

- The CALLER IQ indicator will turn on.

Updating the rate table (downloading the rate table)

If you register through openLCR web site or move to another area, you have to download the rate table manually.

Using the handset

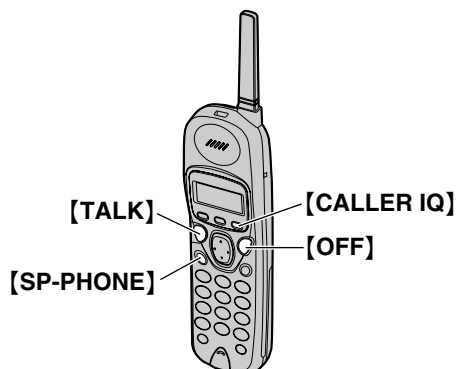

1 Press **[TALK]** or **[SP-PHONE]**, and then, press **[CALLER IQ]**.

2 Press **[#]**.

- The unit will dial to openLCR automatically and start downloading information.

3 When downloading is complete, a beep sounds.

- After downloading starts, the handset must be off-hook. DO NOT PLACE the handset on the base unit (placing the handset on the base unit will terminate the download process). DO NOT PRESS **[OFF]** (pressing **[OFF]** will terminate the download process).
- If the display shows the following, the Caller IQ feature is set to off.

```
Set Caller IQ  
to on.
```

Set the Caller IQ feature to on by referring to page 113.

- If the display shows the following, the unit was unable to download from openLCR.

Download
incomplete.
Try again.

Try downloading manually again.

- If the display shows the following, the unit was unable to download an entry in the directory, because the directory memory is full.

Download
incomplete.
Directory full.

Erase unnecessary entries (page 45).

Using the base unit

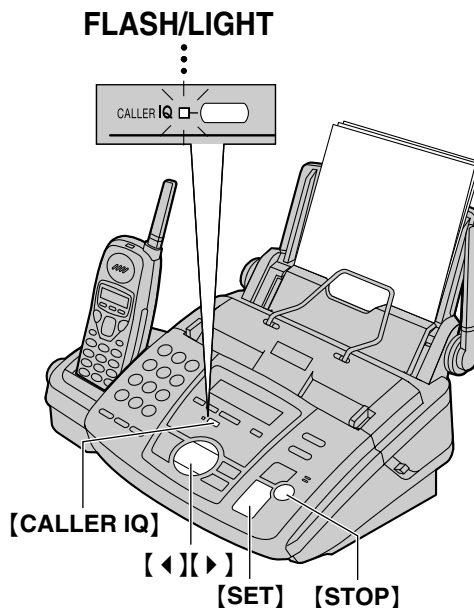

- 1 Press **[CALLER IQ]**.

CALLER IQ
PRESS NAVI. [< >]

- 2 Press **[<]** or **[>]** until the following is displayed or press **[#]**.

GET NEW INFO.
PRESS SET

- 3 Press **[SET]**.

LISTEN & FOLLOW
PHONE GUIDANCE.

- 4 Follow the voice prompt to start downloading.

Caller IQ Feature

During download

- The CALLER IQ indicator will flash and the display will show the following.

DOWNLOADING

- During downloading, you cannot do other operations such as making/answering a call or sending/receiving a document.
- Depending on where you live, the call for downloading may be a long distance call and will take about 1-2 minutes. You will be charged for the cost of the call.
- When the download is completed, the CALLER IQ indicator will stop flashing but will remain lit up and the display will show the following:

DOWNLOAD OK!

- If the display shows the following, the unit was unable to download from openLCR.

DOWNLOAD ERROR.
TRY AGAIN.

Try downloading manually again.

Automatic download

The fax machine will automatically download the latest rate table when:

- the rate table in the fax machine reaches expiry date; usually between 60-90 days after last update,
- the fax machine is being polled by openLCR service center.

To stop downloading

1. Press **[STOP]**.

CANCEL DOWNLOAD?
YES: SET/NO: STOP

2. Press **[SET]**.

Information Download

This enables you to view information such as weather, lottery results and stock quotes from the LCD display on your openLCR-ready unit. Each time you download the data from openLCR, the information will be updated. To view up-to-date information, you will need to download to your unit.

If you access openLCR web site at **www.openLCR.com** and program the system setup and telephone directory, you will need to download this data to the fax machine.

Downloading information using the handset

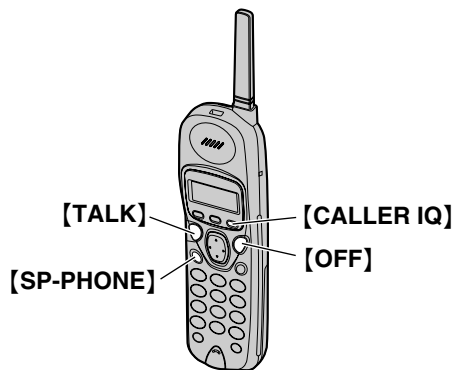

- 1 Press **[TALK]** or **[SP-PHONE]**, and then press **[CALLER IQ]**.

To get new Info., please press #.

- 2 Press **[#]**.
 - The unit will dial to openLCR automatically.

Talk Listen & follow phone guidance.

3 Follow the voice prompt to start downloading.

- When the downloading starts, the display will show the following.

Download in process.
Please wait.

- After downloading starts, the handset must be off-hook. **DO NOT PLACE** the handset on the base unit (placing the handset on the base unit will terminate the download process). **DO NOT PRESS [OFF]** (pressing **[OFF]** will terminate the download process).

4 When downloading is complete, a beep sounds.

Download OK!

- If 3 beeps sound and the following is displayed, some items cannot be stored in the directory.

Download incomplete.
Directory full.

Erase entries which do not exist on the web from the directory of the unit (page 45). Then, start again from step 1.

- You cannot access the openLCR server if a telephone or fax machine on the same phone line is in use.
- While the unit is downloading the data from openLCR, the Call Waiting Service cannot be used.

Downloading information using the base unit

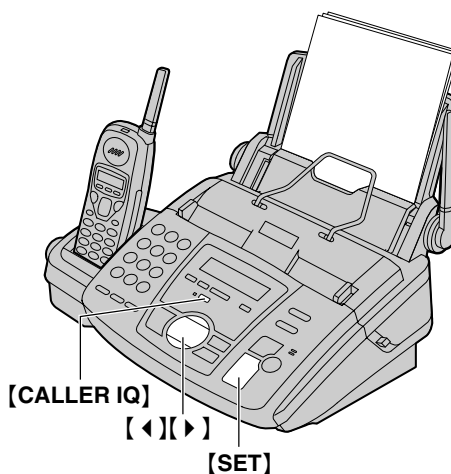

1 Press **[CALLER IQ]**.

CALLER IQ
PRESS NAVI. [◀ ▶]

2 Press **[◀]** or **[▶]** until the following is displayed or press **[#]**.

GET NEW INFO.
PRESS SET

3 Press **[SET]**.

LISTEN & FOLLOW
PHONE GUIDANCE.

4 Follow the voice prompt to start downloading.

DOWNLOADING



DOWNLOAD OK!

Caller IQ Feature

Viewing information using the handset



- 1 Press **[CALLER IQ]**.

```
Press "1" or "#".  
1:View Info.  
#:Get new Info.
```

- 2 Press **[1]**.

- The items of information which you selected on the web are displayed.

Example:

```
1:Weather  
2:Lottery  
3:Stock
```

- 3 Select the desired information by pressing **[1]** to **[3]**.

Example:

```
6-28 12:58pm  
Fort Collins CO  
78 F PartlyCldy
```

- 4 Find more information by pressing **[▼]** or **[▲]**.

Example:

```
H 90 L 70 F  
UV 2 Dew 64 F  
Humidity 42%
```

- 5 When finished, press **[OFF]** or place the handset on the base unit.

```
[Caller IQ on]  
  
[■■■■]
```

Printing information using the base unit

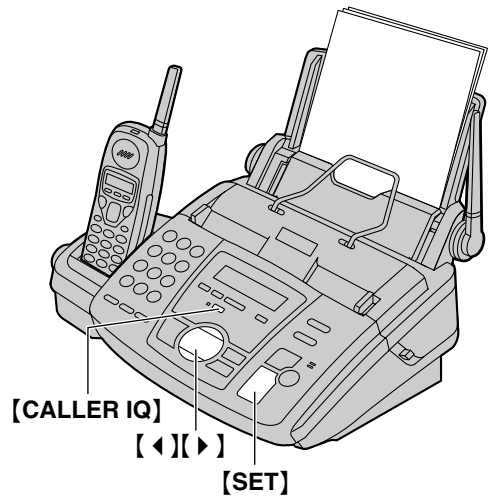

- 1 Press **[CALLER IQ]**.

```
CALLER IQ  
PRESS NAVI. [◀ ▶]
```

- 2 Press **[◀]** or **[▶]** until the following is displayed or press **[1]**.

```
PRINT INFO.  
PRESS SET
```

- 3 Press **[SET]** to start printing.

```
PRINTING
```

Technical data about this product

Base unit

Applicable lines:	Public Switched Telephone Network
Document size:	Max. 216 mm (8 ¹ / ₂ ") in width, Max. 600 mm (23 ⁵ / ₈ ") in length
Effective scanning width:	208 mm (8 ³ / ₁₆ ")
Effective printing width:	208 mm (8 ³ / ₁₆ ")
Transmission time^{*1}:	Approx. 9 s/page (Original mode) ^{*2}
Scanning density:	Horizontal: 8 pels/mm (203 pels/inch) Vertical: 3.85 lines/mm (98 lines/inch) – in standard resolution, 7.7 lines/mm (196 lines/inch) – in fine/photo resolution, 15.4 lines/mm (392 lines/inch) – in super fine resolution
Photo resolution:	64-level
Scanner type:	Contact Image Sensor
Printer type:	Thermal Transfer on plain paper
Data compression system:	Modified Huffman (MH), Modified READ (MR)
Modem speed:	14,400 / 12,000 / 9,600 / 7,200 / 4,800 / 2,400 bps; Automatic Fallback
Operating environment:	5 °C–35 °C (41 °F–95 °F), 20%–80% RH (Relative Humidity)
Dimensions:	Approx. height 199 mm × width 384 mm × depth 282 mm (7 ²⁷ / ₃₂ " × 15 ¹ / ₈ " × 11 ³ / ₃₂ ")
Mass (Weight):	Approx. 3.3 kg (7.3 lb.)
Power consumption:	Standby: Approx. 5.8 W Transmission: Approx. 22 W Reception: Approx. 43 W (When receiving a 20% black document) Copy: Approx. 45 W (When copying a 20% black document) Maximum: Approx. 135 W (When copying a 100% black document)
Power supply:	120 V AC, 60 Hz
Fax memory capacity:	Approx. 25 pages of memory transmission Approx. 28 pages of memory reception (Based on the ITU-T No. 1 Test Chart in standard resolution.)
Voice memory capacity^{*3}:	Approx. 18 minutes of recording time including greeting messages

Handset

Operating environment:	5 °C–40 °C (41°F–104 °F), 20%–80% RH (Relative Humidity)
Dimensions:	Approx. height 42 mm × width 54 mm × depth 246 mm (1 ²¹ / ₃₂ " × 2 ¹ / ₈ " × 9 ¹¹ / ₁₆ ")
Mass (Weight):	Approx. 228 g (0.5 lb.)
Power supply:	Nickel cadmium battery (3.6 V, 850 mAh)
Frequency:	2,402 MHz–2,480 MHz

*1 Transmission speed depends upon the contents of the pages, resolution, telephone line conditions and capability of the other party's machine.

*2 Transmission speed is based upon the ITU-T No. 1 Test Chart and original mode. If the capability of the other party's machine is inferior to your unit, the transmission time may be longer.

*3 Recording time may be reduced by the calling party's background noise.

ITU-T No. 1 Test Chart

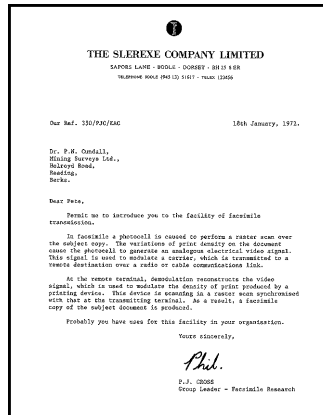

Paper specifications

Recording paper size: Letter: 216 mm × 279 mm (8¹/₂" × 11")
Legal: 216 mm × 356 mm (8¹/₂" × 14")
A4: 210 mm × 297 mm (8¹/₄" × 11¹/₁₆")

Note for recording paper:

- Do not use the following types of paper:
 - Paper with a cotton and/or fiber content that is over 20%, such as letterhead paper or paper used for resumes
 - Extremely smooth or shiny paper, or paper that is highly textured
 - Coated, damaged or wrinkled paper
 - Paper with irregularities, such as tabs or staples
 - Paper which has dust, lint or oil stains
 - Paper that will melt, vaporize, discolor, scorch or emit dangerous fumes, near 200 °C (392 °F), such as vellum paper. These materials may transfer onto the fusing roller and cause damage.
 - Moist paper
- Some paper only accepts print on one side. Try using the other side of the paper if you are not happy with the print quality or if misfeeding occurs.
- For proper feeding and best print quality, we recommend using long-grained paper.
- Do not use paper of different types or thickness at the same time. This may cause a paper jam.
- Avoid double-sided printing.
- Do not use paper printed from this unit for double-sided printing with other copiers or printers. This may cause a paper jam.
- To avoid curling, do not open paper packs until you are ready to use the paper. Store unused paper in the original packaging, in a cool and dry location.

Note:

- Any details given in these instructions are subject to change without notice.
- The pictures and illustrations in these instructions may vary slightly from the actual product.

FCC and Other Information

This equipment complies with Part 68 of the FCC rules and the requirements adopted by the ACTA. On the rear of this equipment is a label that contains, among other information, a product identifier in the format US:ACJ-----.

If requested, this number must be provided to the telephone company.

- Registration No. (found on the rear of the unit)
- Ringer Equivalence No. (REN)
..... (found on the rear of the unit)

A plug and jack used to connect this equipment to the premises wiring and telephone network must comply with the applicable FCC Part 68 rules and requirements adopted by the ACTA. A compliant telephone cord and modular plug is provided with this product. It is designed to be connected to a compatible modular jack that is also compliant.

The REN is used to determine the number of devices that may be connected to a telephone line. Excessive RENs on a telephone line may result in the devices not ringing in response to an incoming call. In most but not all areas, the sum of RENs should not exceed five (5.0). To be certain of the number of devices that may be connected to a line, as determined by the total RENs, contact the local telephone company. For products approved after July 23, 2001, the REN for this product is part of the product identifier that has the format US:AAAEQ##TXXXX. The digits represented by ## are the REN without a decimal point (e.g., 03 is a REN of 0.3).

If this equipment causes harm to the telephone network, the telephone company will notify you in advance that temporary discontinuance of service may be required. But if advance notice isn't practical, the telephone company will notify the customer as soon as possible. Also, you will be advised of your right to file a complaint with the FCC if you believe it is necessary.

The telephone company may make changes in its facilities, equipment, operations or procedures that could affect the operation of the equipment. If this happens the telephone company will provide advance notice in order for you to make necessary modifications to maintain uninterrupted service.

If trouble is experienced with this equipment, for repair or warranty information, please contact a Factory Servicenter or other Authorized Servicer. If the equipment is causing harm to the telephone network, the telephone company may request that you disconnect the equipment until the problem is resolved.

Connection to party line service is subject to state tariffs. Contact the state public utility commission, public service commission or corporation commission for information.

This equipment is hearing aid compatible as defined by the FCC in 47 CFR Section 68.316.

When you hold the phone to your ear, noise might be heard in your Hearing Aid. Some Hearing Aids are not adequately shielded from external RF (radio frequency) energy. If noise occurs, use an optional headset accessory or the speakerphone option (if applicable) when using this phone. Consult with your audiologist or Hearing Aid manufacturer about the availability of Hearing Aids which provide adequate shielding to RF energy commonly emitted digital devices.

If your home has specially wired alarm equipment connected to the telephone line, ensure the installation of this equipment does not disable your alarm equipment. If you have questions about what will disable alarm equipment, consult your telephone company or a qualified installer.

WHEN PROGRAMMING EMERGENCY NUMBERS AND (OR) MAKING TEST CALLS TO EMERGENCY NUMBERS:

- 1) Remain on the line and briefly explain to the dispatcher the reason for the call.
- 2) Perform such activities in the off-peak hours, such as early morning or late evenings.

The software contained in this equipment to allow user access to the network must be upgraded to recognize newly established network area codes and exchange codes as they are placed into service. Failure to upgrade the premises systems or peripheral equipment to recognize the new codes as they are established will restrict the customer and the customer's employees from gaining access to the network and to these codes.

This device complies with Part 15 of the FCC Rules. Operation is subject to the following two conditions:

- (1) This device may not cause harmful interference, and
- (2) this device must accept any interference received, including interference that may cause undesired operation.

Privacy of communications may not be ensured when using this phone.

CAUTION:

Any changes or modifications not expressly approved by the party responsible for compliance could void the user's authority to operate this device.

FCC and Other Information

NOTE:

This equipment has been tested and found to comply with the limits for a Class B digital device, pursuant to Part 15 of the FCC Rules. These limits are designed to provide reasonable protection against harmful interference in a residential installation. This equipment generates, uses, and can radiate radio frequency energy and, if not installed and used in accordance with the instructions, may cause harmful interference to radio communications. However, there is no guarantee that interference will not occur in a particular installation. If this equipment does cause harmful interference to radio or television reception, which can be determined by turning the equipment off and on, the user is encouraged to try to correct the interference by one or more of the following measures:

- Reorient or relocate the receiving antenna.
- Increase the separation between the equipment and receiver.
- Connect the equipment into an outlet on a circuit different from that to which the receiver is connected.
- Consult the dealer or an experienced radio/TV technician for help.

CAUTION:

To comply with FCC RF exposure requirements, the base unit should be installed with its antenna located at 20 cm or more from persons and handset should be carried with the specific belt-clip provided for the handset to ensure compliance. Other non-tested belt-clips or similar body-worn accessories may not comply, therefore, should be avoided.

Limited Warranty

PANASONIC CONSUMER ELECTRONICS COMPANY,
DIVISION OF MATSUSHITA ELECTRIC
CORPORATION OF AMERICA
One Panasonic Way,
Secaucus, New Jersey 07094

PANASONIC SALES COMPANY,
DIVISION OF MATSUSHITA
ELECTRIC OF PUERTO RICO, INC.,
Ave. 65 de Infantería, Km. 9.5
San Gabriel Industrial Park,
Carolina, Puerto Rico 00985

Panasonic Facsimile Product Limited Warranty

Limited Warranty Coverage

If your product does not work properly because of a defect in materials or workmanship, Panasonic Consumer Electronics Company or Panasonic Sales Company (collectively referred to as “the warrantor”) will, for the length of the period indicated on the chart below, which starts with the date of original purchase (“warranty period”), at its option either (a) repair your product with new or refurbished parts, or (b) replace it with a new or a refurbished product. The decision to repair or replace will be made by the warrantor.

FAX categories	Parts	Labor
Thermal Transfer Facsimile	6 Months	6 Months
Laser Facsimile	1 (one) Year	1 (one) Year

Batteries, antennas, ink film, toner cartridge, drum unit, and ink cartridge (as may be applicable), and cosmetic parts (cabinet) are not warranted under this Limited Warranty.

During the “Labor” warranty period there will be no charge for labor. During the “Parts” warranty period, there will be no charge for parts. You must carry-in or mail-in your product during the warranty period. This warranty only applies to products purchased and serviced in the United States or Puerto Rico. This warranty is extended only to the original purchaser of a new product which was not sold “as is”. A purchase receipt or other proof of the original purchase date is required for warranty service.

Carry-In or Mail-In Service

For Carry-In or Mail-In Service in the United States call 1-800-HELP-FAX (1-800-435-7329)
For assistance in Puerto Rico call Panasonic Sales Company (787)-750-4300 or fax (787)-768-2910.

Limited Warranty Limits And Exclusions

This warranty ONLY COVERS failures due to defects in materials or workmanship, and DOES NOT COVER normal wear and tear or cosmetic damage. The warranty ALSO DOES NOT COVER damages which occurred in shipment, or failures which are caused by products not supplied by the warrantor such as non Panasonic ink film, toner cartridge or drum unit, or failures which result from accidents, misuse, abuse, neglect, mishandling, misapplication, alteration, faulty installation, set-up adjustments, signal reception problems, misadjustment of consumer controls, improper maintenance, power line surge, improper voltage supply, lightning damage, modification, or commercial use (such as in a hotel, office, restaurant, or other business), rental use of the product, service by anyone other than a Factory Servicer or other Authorized Servicer, or damage that is attributable to acts of God.

THERE ARE NO EXPRESS WARRANTIES EXCEPT AS LISTED UNDER “LIMITED WARRANTY COVERAGE”. THE WARRANTOR IS NOT LIABLE FOR INCIDENTAL OR CONSEQUENTIAL DAMAGES RESULTING FROM THE USE OF THIS PRODUCT, OR ARISING OUT OF ANY BREACH OF THIS WARRANTY. (As examples, this excludes damages for lost time, cost of having someone remove or re-install an installed unit if applicable, or travel to and from the servicer. The items listed are not exclusive, but are for illustration only.) **ALL EXPRESS AND IMPLIED WARRANTIES, INCLUDING THE WARRANTY OF MERCHANTABILITY, ARE LIMITED TO THE PERIOD OF THE LIMITED WARRANTY.**

Warranty

Some states do not allow the exclusion or limitation of incidental or consequential damages, or limitations on how long an implied warranty lasts, so the exclusions may not apply to you.

This warranty gives you specific legal rights and you may also have other rights which vary from state to state. If a problem with this product develops during or after the warranty period, you may contact your dealer or Servicenter. If the problem is not handled to your satisfaction, then write to the warrantor's Consumer Affairs Department at the addresses listed for the warrantor.

PARTS AND SERVICE WHICH ARE NOT COVERED BY THIS LIMITED WARRANTY ARE YOUR RESPONSIBILITY.

For product service

- Call toll-free 1-800-HELP-FAX (1-800-435-7329) for the location of an authorized servicenter.

For out of warranty technical support

- After the warranty has expired, please contact our Continued Services Technical Support Line at 1-900-555-PANA (1-900-555-7262) for support on a fee basis.

When you ship the product

- Carefully pack your unit, preferably in the original carton.
- Attach a letter, detailing the symptom or problem, to the outside of the carton.
- Send the unit to an authorized servicenter, prepaid and adequately insured.
- Do not send your unit to the Panasonic Consumer Electronics Company or to any executive or regional sales office. These locations do not repair consumer products.

Customer Services directory

**To obtain service or technical assistance during the warranty period, please contact: 1-800-HELP-FAX (1-800-435-7329), Monday-Friday 9am-8pm EST.
To obtain support or service after the warranty has expired, please contact: 1-900-555-PANA (1-900-555-7262) for support on a fee basis.
For hearing or speech impaired TTY users, TTY: 1-866-741-6422**

**Web Site: www.panasonic.com
(for customers in the USA or Puerto Rico ONLY)
You can purchase parts, accessories or locate your nearest servicer by visiting our Web Site.**

**Service in Puerto Rico
Matsushita Electric of Puerto Rico, Inc. Panasonic Sales Company / Factory Servicer:
Ave. 65 de Infantería, Km. 9.5, San Gabriel Industrial Park, Carolina, Puerto Rico 00985
Phone (787) 750-4300 Fax (787) 768-2910**

Program index

Basic feature

#01 Date and time.....	31
#02 Your logo.....	32
#03 Your fax number	34
#04 Sending report	56, 88
#06 FAX ring setting	88
#06 TAD ring setting	65, 88
#10 Recording time for an incoming message	88
#11 Remote operation ID	88
#13 Dialing mode	88
#16 Paper size	88
#17 Ringer pattern	30, 88

Advanced feature

#22 Journal report.....	56, 89
#23 Overseas mode.....	89
#25 Delayed transmission.....	89
#26 Caller ID list.....	89
#31 Distinctive Ring	66
#32 Ring pattern	89
#34 Quick scan	56, 68, 89
#36 Receiving reduction	90
#39 Display contrast	90
#41 Fax activation code	25, 90
#42 Message alert	90
#43 Recording time alert.....	90
#44 Memory reception alert	90
#46 Friendly reception	90
#47 Fax voice guidance	91
#51 Mailbox 1 password	91
#52 Mailbox 2 password	91
#54 Greeting time	91
#55 Mailbox 1 greeting.....	91
#56 Mailbox 2 greeting.....	91
#60 Message transfer	84, 91
#61 Message transfer greeting message	84, 91
#67 Incoming message monitor	91
#70 Pager call.....	91
#76 Connecting tone.....	92
#77 Auto answer	92
#80 Reset advanced features	92

Index

- A** Accessories.....9
 A4 paper guide 16
 Belt clip..... 19
 Legal paper tray 16
 Metal recording paper guide..... 17
 Paper tray 16
 Auto talk feature 37
 Advanced features 89
 Alert
 Memory reception (Feature #44)..... 90
 Message (Feature #42)..... 90
 Recording time (Feature #43) 90
 Auto answer setting (Feature #77) 92
- B** Basic features 88
 Battery
 Charging.....3, 21
 Life.....21
 Replacing 107
 Broadcast transmission..... 59
 Buttons/Keys
 AUTO ANSWER..... 62, 64
 CALLER ID..... 51
 CALLER IQ..... 112, 113
 CALL WAIT..... 49
 CLEAR 45, 52
 Delete 33
 DIGITAL SP-PHONE 35, 37
 ERASE 75, 81
 FUNCTION..... 36, 37, 41
 HELP 28
 HOLD 35
 Insert 33
 INTERCOM 38, 40
 LOCATOR/INTERCOM 38, 40
 OFF 35, 37
 PLAYBACK..... 76
 QUICK 74
 REDIAL 55
 SLOW 74
 SP-PHONE..... 35, 37
 TALK..... 35, 37
- C** Caller ID 49
 Calling back..... 50
 Storing 54
 Caller ID list (Feature #26)..... 49
 Caller's recording time (Feature #10)..... 88
 Character table..... 33
 Cleaning..... 108
- Communication messages..... 93
 Connecting tone (Feature #76) 92
 Copy..... 68
 Collation 70
 Enlarge 69
 Reduce 69
- D** Date and time (Feature #01) 31, 88
 Delayed transmission (Feature #25) 89
 Dialing mode (Feature #13) 88
 Display
 Contrast (Feature #39) 90
 Error messages 94
 Distinctive Ring service
 (Feature #31) 66, 89
 Document size 57
- E** Erasing recorded messages 75
 Error messages..... 93, 94
- F** Fax activation code (Feature #41)..... 90
 Fax auto redial 58
 Fax number (Feature #03) 34, 88
 Fax receiving..... 62
 Fax voice guidance (Feature #47)..... 91
 Friendly reception (Feature #46)..... 90
- G** Greeting message
 Message transfer (Feature #61) 84, 91
 TAD/FAX 71
 Voice mailbox (Feature #55, #56).... 80, 91
- H** Handset locator..... 39
 Headset..... 19
 Help..... 28
- I** Incoming message monitor
 (Feature #67) 91
 Ink film
 Installing 14
 Replacing 101
- J** Jams
 Document..... 106
 Recording paper..... 103, 105
 Journal report (Feature #22)..... 56, 89
- L** Logo (Feature #02) 32, 88
- M** Memory redial 35
 Message alert (Feature #42)..... 90
 Message transfer (Feature #60)..... 84, 91

Index

- N** Navigator directory
 - Making a phone call 47
 - Selecting characters..... 33, 41
 - Sending faxes..... 58
 - Storing..... 41
- O** Overseas mode (Feature #23)..... 89
- P** Pager call (Feature #70) 91
- Paper size (Feature #16) 88
- Power failure 100
- Q** Quick scan (Feature #34) 56, 68, 89
- R** Receiving alert (Feature #44) 90
- Receiving reduction (Feature #36)..... 90
- Recording
 - Greeting message 71, 80, 84
 - Memo message..... 73, 81
- Recording paper 18
- Recording paper size 120
- Recording time alert (Feature #43) 90
- Recording time for TAD/FAX greeting message (Feature #54)..... 91
- Remote operation card 129
- Remote operation ID (Feature #11) 88
- Reports
 - Broadcast programming..... 111
 - Broadcast sending..... 61
 - Caller ID list..... 49, 89, 111
 - Journal..... 56, 111
 - Power down..... 100
 - Printer test 111
 - Sending 56, 88
 - Setup 111
 - Telephone number 111
- Reset (Feature #80)..... 92
- Resolution 55, 68
- Ringer pattern for base unit (Feature #17) 30, 88
- Ringer pattern for handset 29
- Ring pattern for Distinctive Ring (Feature #32) 89
- Ring setting
 - FAX ONLY (Feature #06)..... 88
 - TAD/FAX (Feature #06) 88
- S** Sending
 - Broadcast 61
 - From memory..... 56
 - Manually 55
 - Navigator directory 58
 - Sending report (Feature #04)..... 56, 88
 - Set default (Feature #80) 92
- Storing
 - Broadcast 59
 - Navigator directory 41
- T** Toll saver 65
- V** Voice mailbox..... 79
- Voice mailbox password (Feature #51, #52) 81, 82, 83, 91
- Voice time/day stamp..... 74
- Volume 29, 30
- W** Warranty 123

Answering device remote operation		
<ol style="list-style-type: none"> 1. Call your unit. 2. Press the remote operation ID during the greeting message. 3. Press the remote command key. <ul style="list-style-type: none"> • To record a message in a mailbox, call your unit, press * and the mailbox no. (1 or 2), then leave a message. • To retrieve messages from a mailbox, call your unit, press * and the mailbox no. (1 or 2), enter the mailbox password, then press the remote command key. 	[4]	New message playback
	[5]	All message playback
	[6]	Room monitor
	[7]	Re-records a greeting message
	[9]	Stops re-recording of a greeting message
	[*][4]	Erases a specific message
	[*][5]	Erases all messages
	[8][0]	Changes to TEL mode
	[8][1]	Turns on message transfer
	[8][2]	Turns off message transfer
Key	Remote command	
[0]	Skips the greeting message	[8][3] Turns on pager call
[1]	Repeats a message	[8][4] Turns off pager call
[2]	Skips a message	[*][9] Activates fax function

Panasonic

KX-FPG372

Proof of Purchase

Panasonic FAX ADVANTAGE PROGRAM

*Free peace of mind,
direct from Panasonic*

NO EXTRA COST



- **6-month limited warranty¹: parts, labor, and toll-free help line²**
- **Free replacement³ and repair program**

The Panasonic Fax Advantage Consumer Service Program.

Panasonic knows that if your fax machine is not up and running, neither is your business. That's why we created the Panasonic Fax Advantage Program. Included at no extra cost with the purchase of a new and unused Panasonic Fax Machine, the Fax Advantage Program can provide a free replacement unit³ if your original unit is in need of repair.

Here's how it works:

1. If you have a problem with your fax that you purchased new and unused while it is covered by the period of limited warranty¹, call our toll-free help-line at 1-800-HELP-FAX².
2. Talk to one of our technical experts to diagnose your problem over the phone.
3. If repairs are necessary and you are entitled to service under the terms and conditions of the limited warranty⁴, we will send a refurbished replacement unit to you by UPS Ground service delivery. The shipping method is upgradable for an extra charge.

A second option available under our limited warranty is to mail-in or carry-in your fax to one of our Regional Service centers, where the unit will be repaired and returned to you.

Instructions:

If you choose to receive a replacement unit under the Fax Advantage Program, Panasonic will provide a replacement unit which will be completely refurbished, quality-tested by Panasonic technicians and individually hand-inspected before it is shipped to you. You will keep the replacement unit and send the original unit to us in the replacement unit's box. UPS will pick up the unit at no charge to you, should it be determined that you are entitled to warranty service. A proof-of-purchase must be included with the returned product. Any unit that is replaced by Panasonic and not shipped with proper proof-of-purchase by you will be subject to a minimum \$100.00 charge. The original unit must be properly packaged in the same manner as the replacement unit, utilizing the packing materials provided. Damage due to improper or inadequate packing will be charged to you as an out-of-warranty cost.

If our 1-800-HELP-FAX technicians determine that your unit may be an "out-of-box failure"⁵, we will attempt to provide you with a factory-new replacement unit⁶. You must ship a copy of your receipt with your original unit to verify that you purchased the unit within 10 days prior to your 1-800-HELP-FAX call.

Requirements:

You must give our technicians a valid credit card number (Discover, VISA, Master Card, or American Express/Optima). Product that is not returned to Panasonic by 10 business days after shipment of the replacement product will be charged to your credit card account at Panasonic's Suggested Retail Price (see dealer for details). If your original unit is not eligible for warranty service, your card will be charged for the non-warranty repair of the unit at Panasonic's current rate for parts and labor and for any shipping charges associated with this program. If you do not wish to pay out-of-warranty repair costs, you will be responsible for returning the replacement unit to Panasonic and for paying all shipping charges associated with this program including the UPS delivery of the replacement product to you, shipment of the problem unit to Panasonic, shipment of the replacement unit back to Panasonic and the return of your original unit back to you. Credit status will be verified prior to sending the replacement product.

1. See dealer for limited warranty details.
2. After the fax advantage program, contact our Continued Services Technical Support Line at 1-900-555-PANA (1-900-555-7262), for fee based technical support.
3. Replacement unit is refurbished.
4. Replacement program is only available in the 50 United States and is subject to termination at any time without advance notice.
5. "Out-of-box failure" is an inoperable unit that was purchased no more than 10 days prior to your 1-800-HELP-FAX call, and would otherwise qualify for warranty service under the terms and conditions of the limited warranty.
6. Panasonic reserves the right to send a refurbished unit.

**Panasonic Consumer Electronics
Company, Division of Matsushita
Electric Corporation of America**

One Panasonic Way,
Secaucus, New Jersey 07094

**Panasonic Sales Company,
Division of Matsushita Electric of
Puerto Rico, Inc.**

Ave. 65 de Infantería, Km. 9.5
San Gabriel Industrial Park, Carolina,
Puerto Rico 00985

PFQX1792ZB CM0702DK1092